

DESCRIPTION: LUMLEY ULTRA-1 LIFT UP 4FT6 BED

1.5 Hr

APPROXIMATE ASSEMBLY TIME

2 PERSON ASSEMBLY

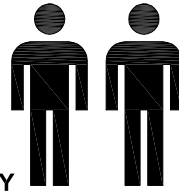

FLOOR AREA
2.5M X 2.5M

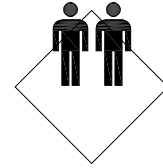

CEILING HEIGHT
2.5M

REQUIRED ASSEMBLY SPACE

REQUIRED ASSEMBLY TOOLS

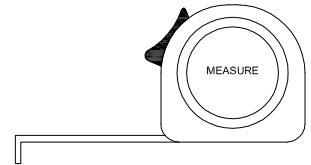

ASSEMBLED DIMENSIONS DOUBLE BED FRAME

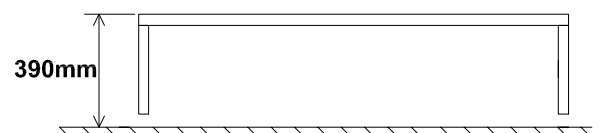
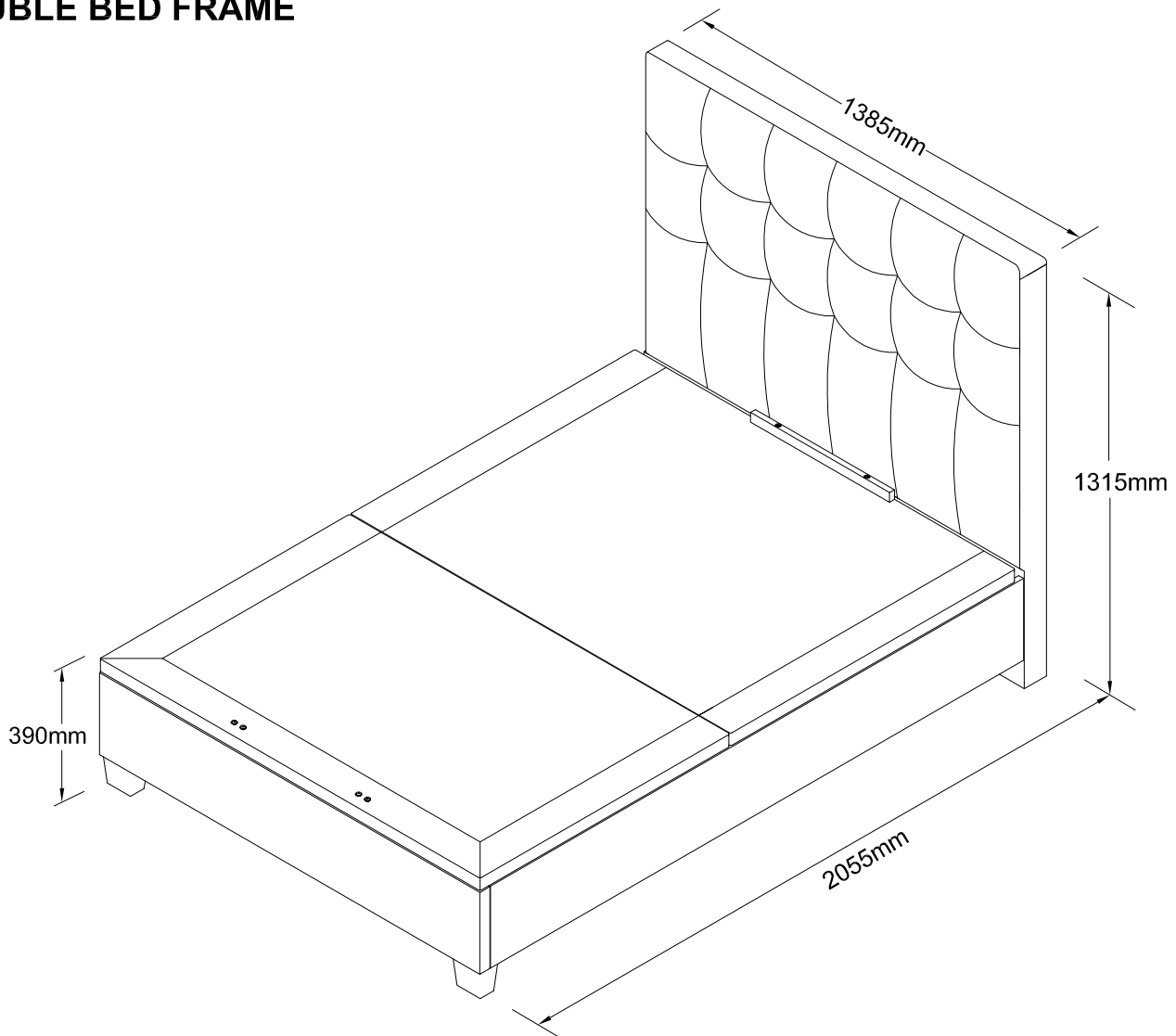

Internal size for mattress = 1350mm x 1900mm

PARTS LIST

NO.	PART LISTS	QTY
1	HEADBOARD	1
2	FOOTBOARD	1
3	SIDE RAIL (L)	1
4	SIDE RAIL (R)	1
5	FRONT LIFT BASE	1
6	BACK LIFT BASE	1
7	BASE PANEL	4
8	MATTRESS SUPPORT RAIL	1
9	LIFT UP MECHANISM (LEFT)	1
10	LIFT UP MECHANISM (RIGHT)	1
11	BOTTOM CROSS RAIL (LONG)	1
12	BOTTOM CROSS RAIL (SHORT)	1

CARTON 1 CONSISTS OF PART : 1
 CARTON 2 CONSISTS OF PART : 2, FB LEGS
 CARTON 3 CONSISTS OF PART : 3,4,8,11,12, HARDWARE
 CARTON 4 CONSISTS OF PART : 5,6
 CARTON 5 CONSISTS OF PART : 7
 CARTON 6 CONSISTS OF PART : 9,10

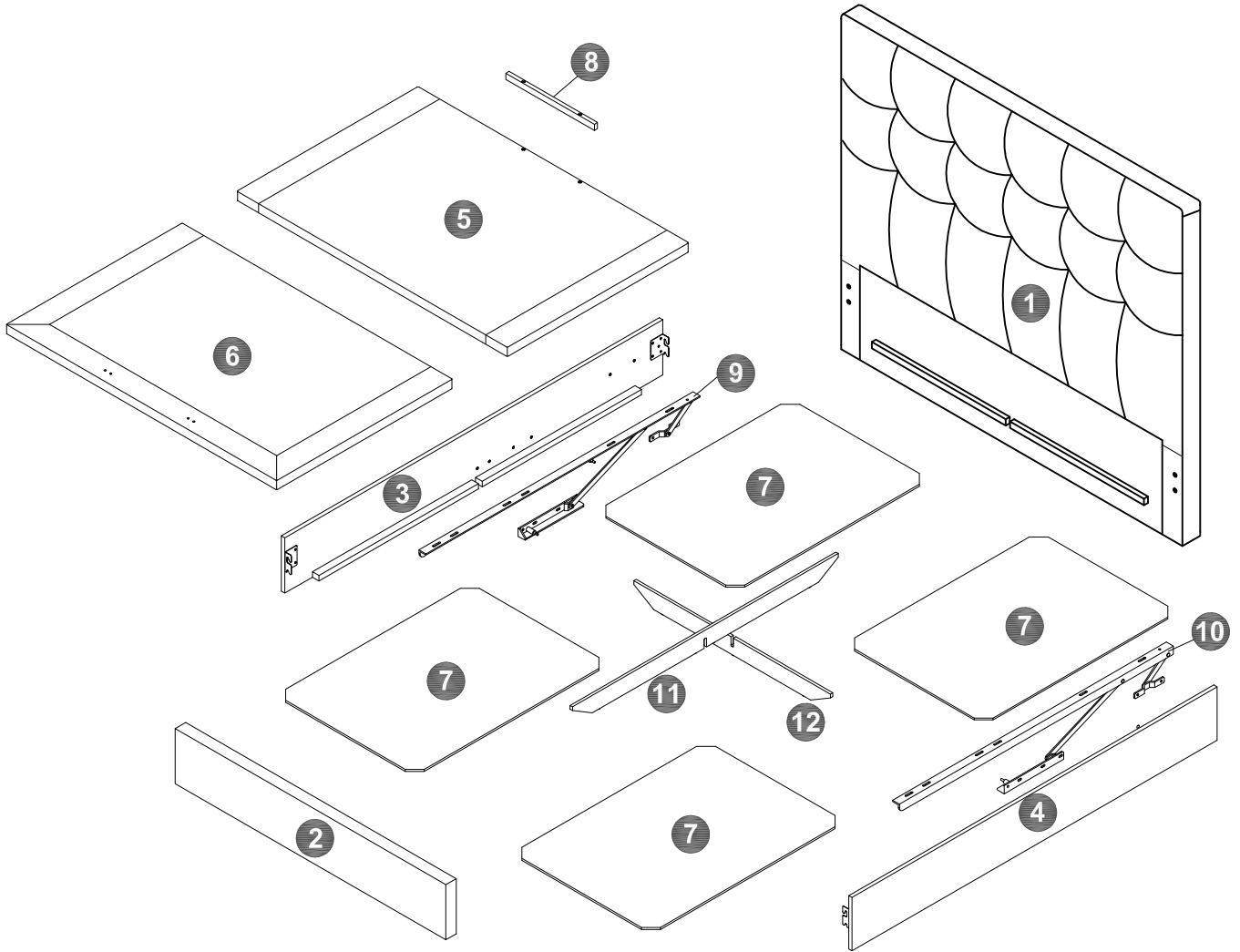

HARDWARE LIST



2x
M8 X 50mm
A
BOLT

12x
M8 X 25mm
B
BOLT

4x
M6 X 20mm
C
BOLT

8x
#8 X 32mm
D
SCREW

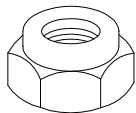

4x
M8 X 13mm
E
LOCK NUT

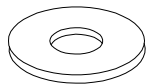

4x
M6 X 16mm
F
FLAT
WASHER

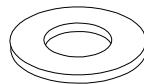

12x
M8 X 18mm
G
FLAT
WASHER

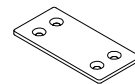

2x
86 X 40mm
H
METAL
PLATE

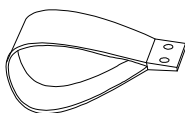

2x
I
STRAP
HANDLE

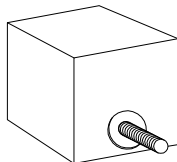

2x
J
FOOTBOARD
LEG



1x
K
ALLEN KEY
(M4)

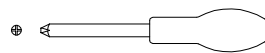

1x
L
SCREW DRIVER
(4" x 5mm)



2x
564 x 900N
M
GAS SPRING

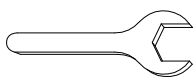

1x
N
SPANNER
(13mm)



2x
O
STUD BOLT
Ø6 X 40mm

Top Tips before you start!

1. Please check that all parts are present before you start the assembly of your furniture, as once assembled, the furniture is exempt from our home approval policy.
2. For ease and speed of assembly, we recommend that before you commence each step of the assembly, that you identify all the parts required for that step.
3. For larger items, please ensure that you have sufficient space and people (as indicated on page 1) to assemble your product safely.
4. We recommend that, where possible, all items are assembled near to the area in which they will be placed in use, to avoid moving the product unnecessarily once assembled.
5. For the protection of your furniture, particularly items of high gloss finish, we recommend that the product is placed on a protected surface during assembly to prevent any damage.
6. During assembly please take care not to over-tighten any fittings, as this may damage the product.
7. Please note: The bed base is in the upright position when first assembled as the gas lifts are fully extended during shipment for safety. After assembly a firm downward push will be required to overcome any resistance in the gas lifts as these may initially stick. We suggest placing a mattress on top of the bed base to aide this and also test the operation of your new lift up bed by lifting and pushing down the bed base a few times to allow the lifting mechanism to bed in.

Care and Maintenance of your Furniture

- Please periodically check all fittings and re-tighten as necessary.
- To clean your item, please use a damp cloth and wipe clean.
- Please do not jump on your furniture.
- Never allow any kind of liquid to remain on your furniture. Absorption can cause finishes to de-laminate.
- Periodically check the condition of your bed slats and plastic locating caps to ensure they are in good condition and have not become loose.
- This is very important when moving your bed. It is best to lift the bed, and never to drag it.
- Please kindly take account of your floor covering when assembling a new bed! If the floor offers little resistance (such as wood or laminate) then it is recommended to use rug or similar be placed under each leg.

DO NOT USE ANY POWER TOOLS AS THIS MAY DAMAGE THE FRAME AND WILL INVALIDATE ANY CLAIM

STEP 1

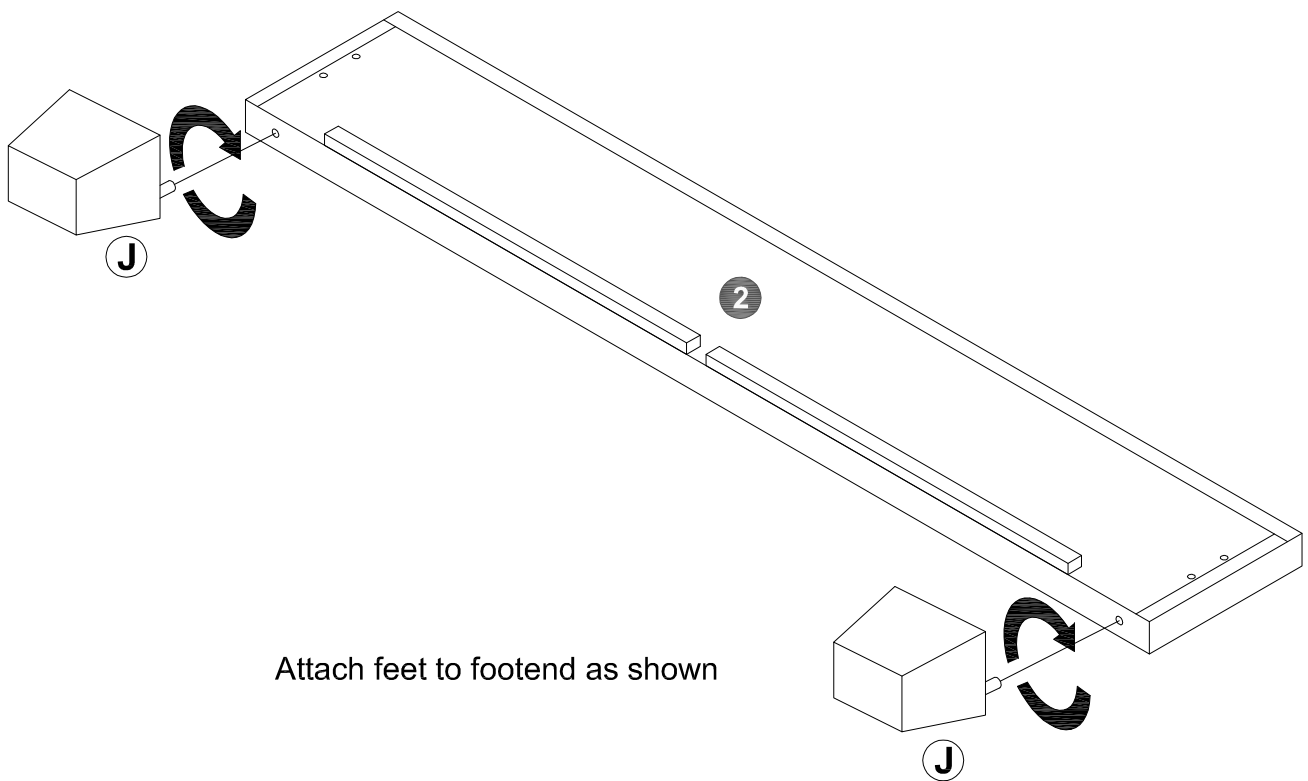
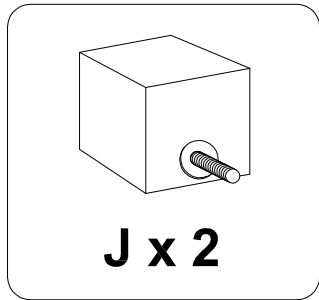

Special Note : For Leg Assembly

Please make sure the bolt thread is correctly matched with the metal nut. Do not over tighten, as this may cross the threads causing damage to the product.

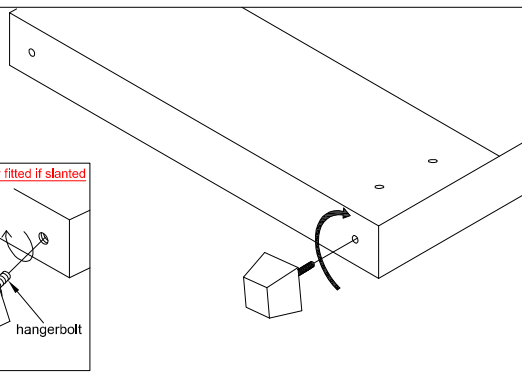
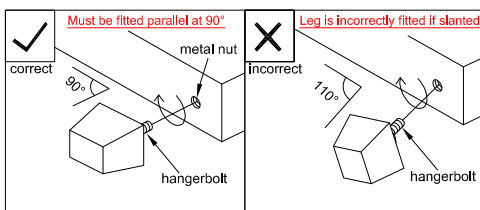

STEP 2

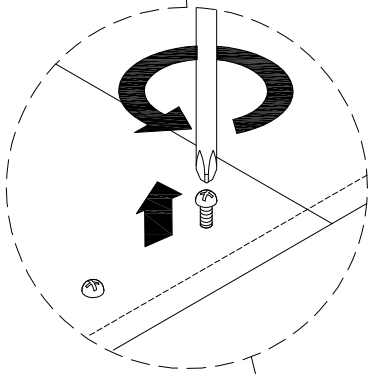
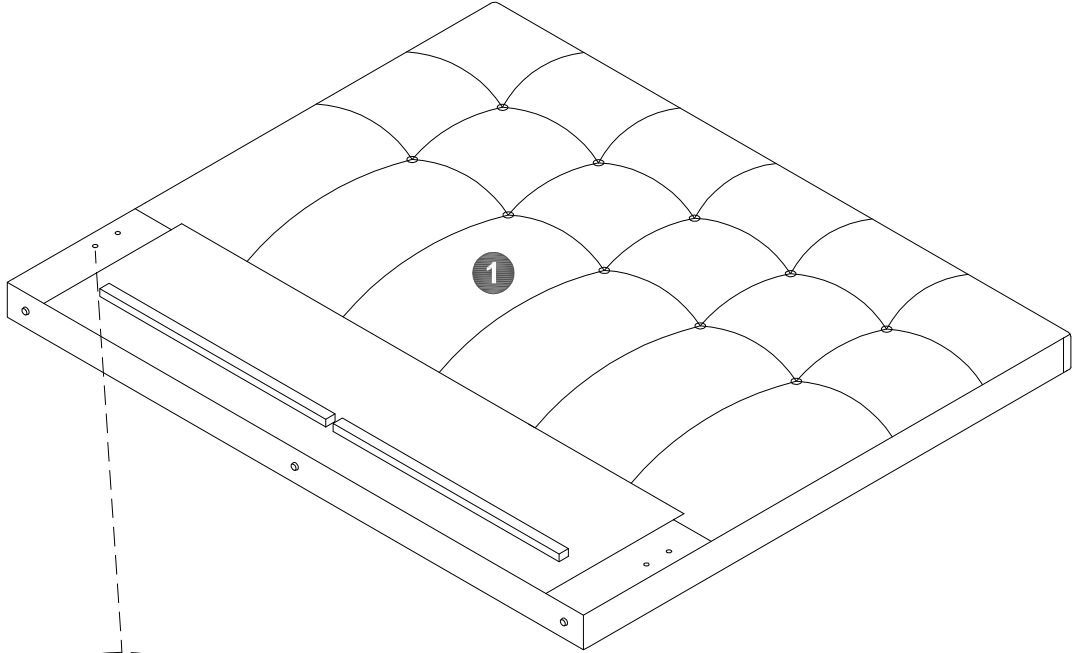
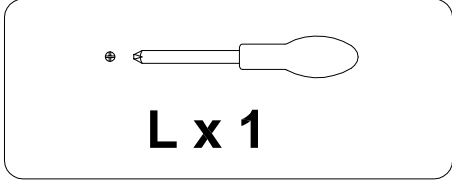

Loosen bolts in headend and footend.
Do not remove.

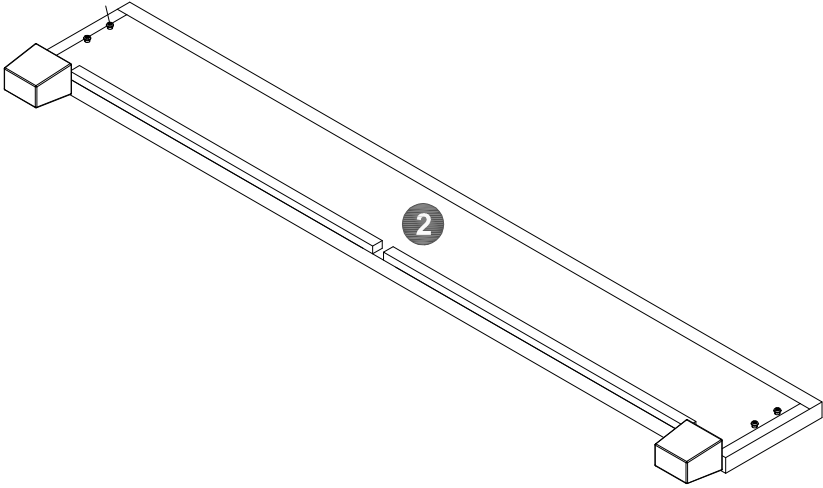

STEP 3

Hook brackets over bolts and tighten with screwdriver provided.

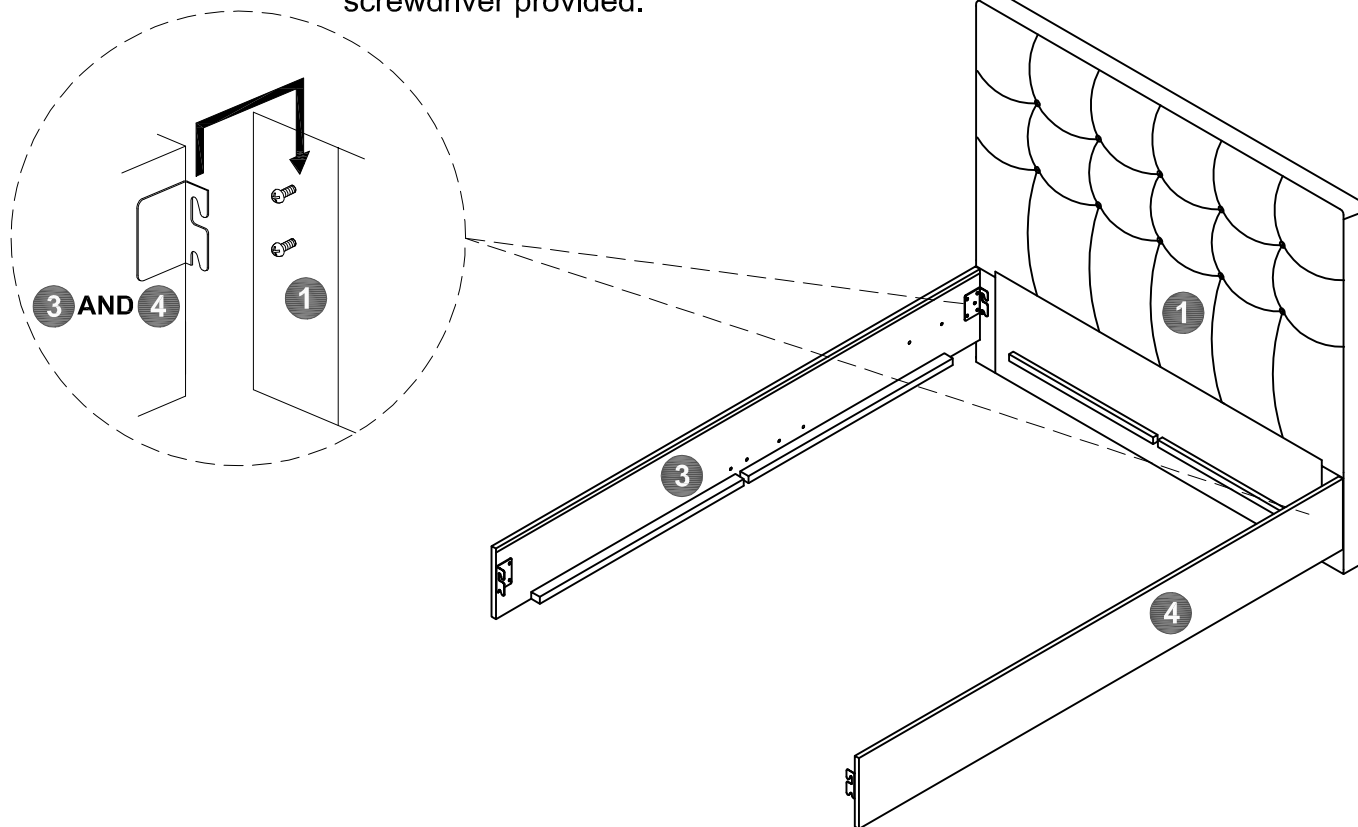

STEP 4

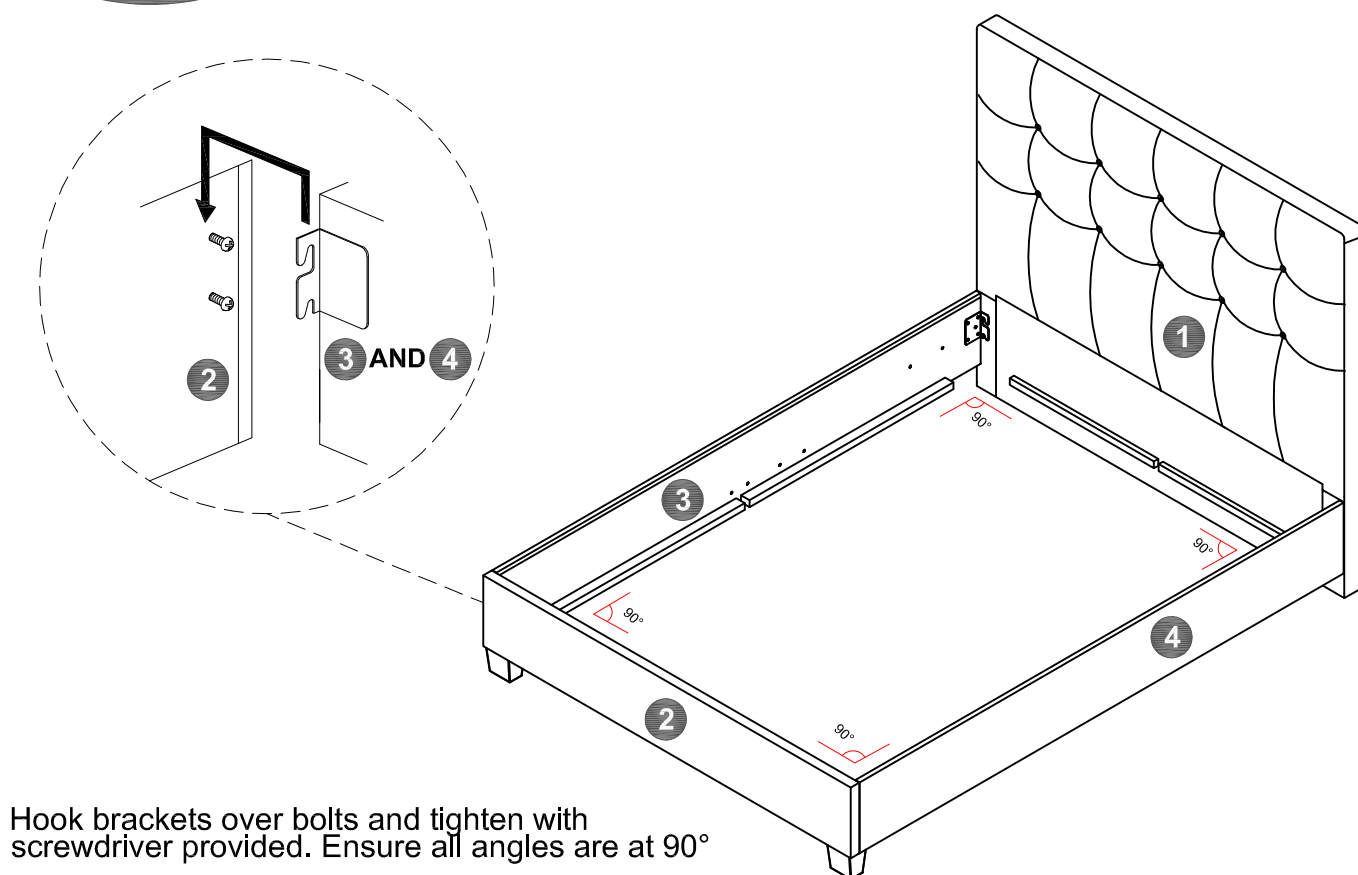

Hook brackets over bolts and tighten with screwdriver provided. Ensure all angles are at 90°

STEP 5

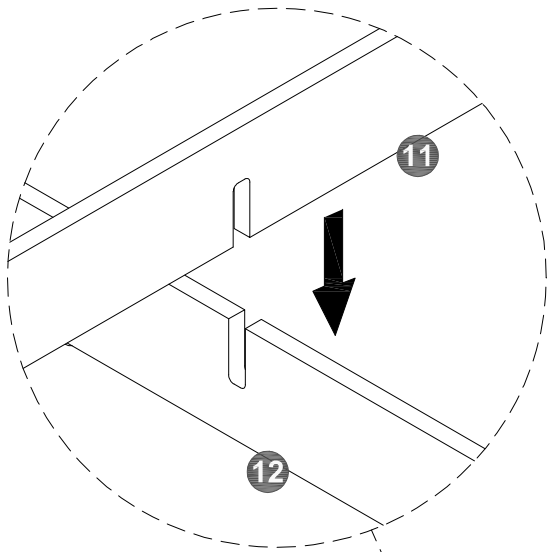

Slot together base panel supports in the cavity of the bed.

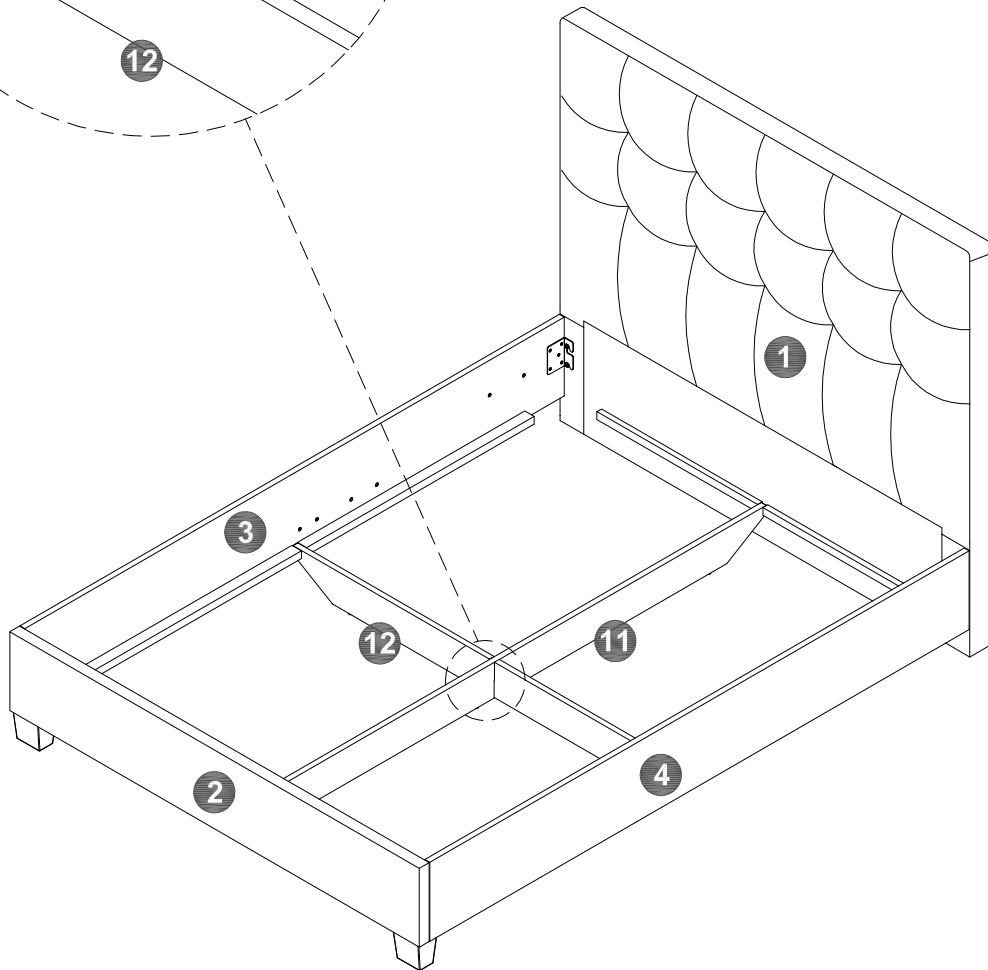

STEP 6

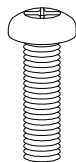

B x 12

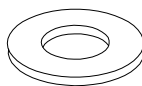

G x 12

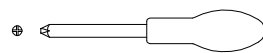

L x 1

Attach mechanisms using fixings and screwdriver provided. (Do not use power tools)

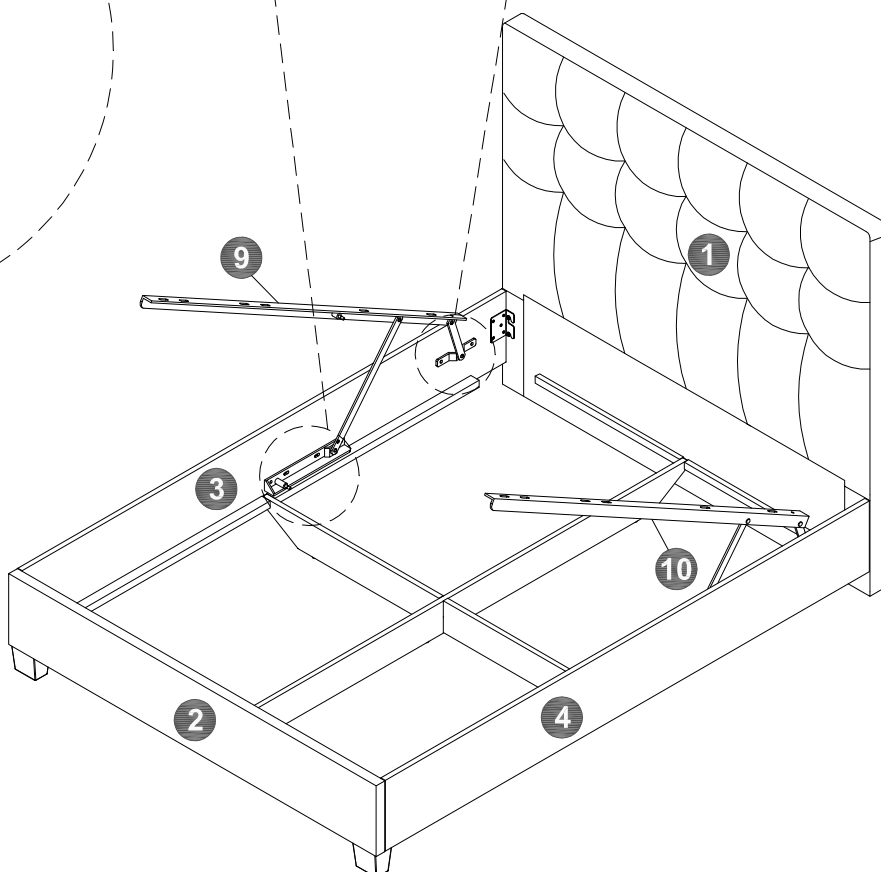
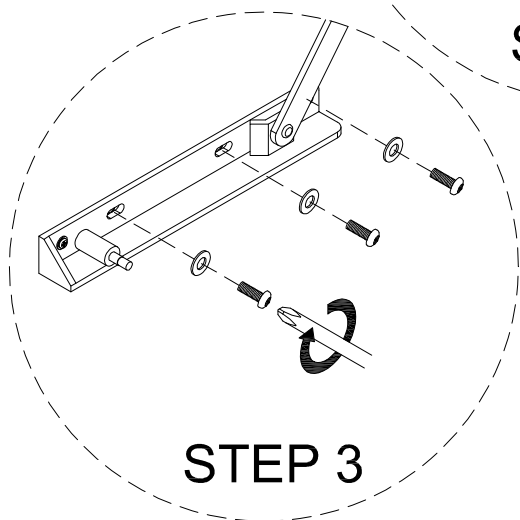
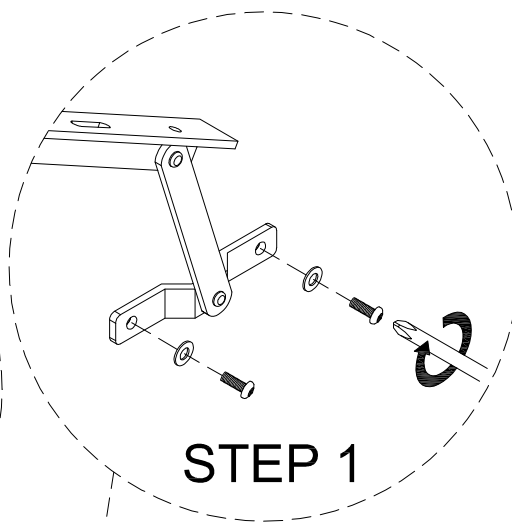
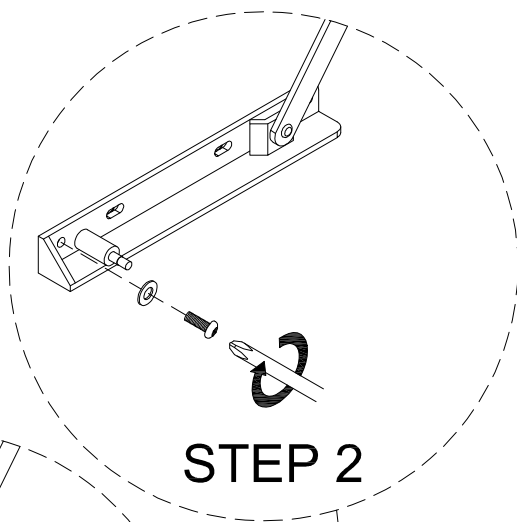

STEP 7



E x 4



M x 2



N x 1

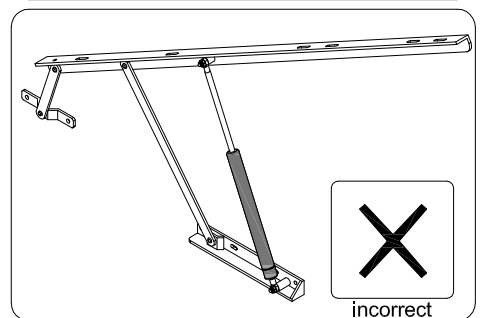
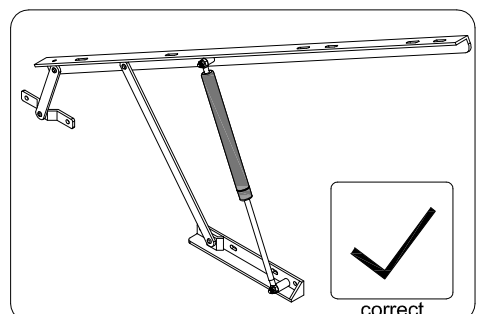
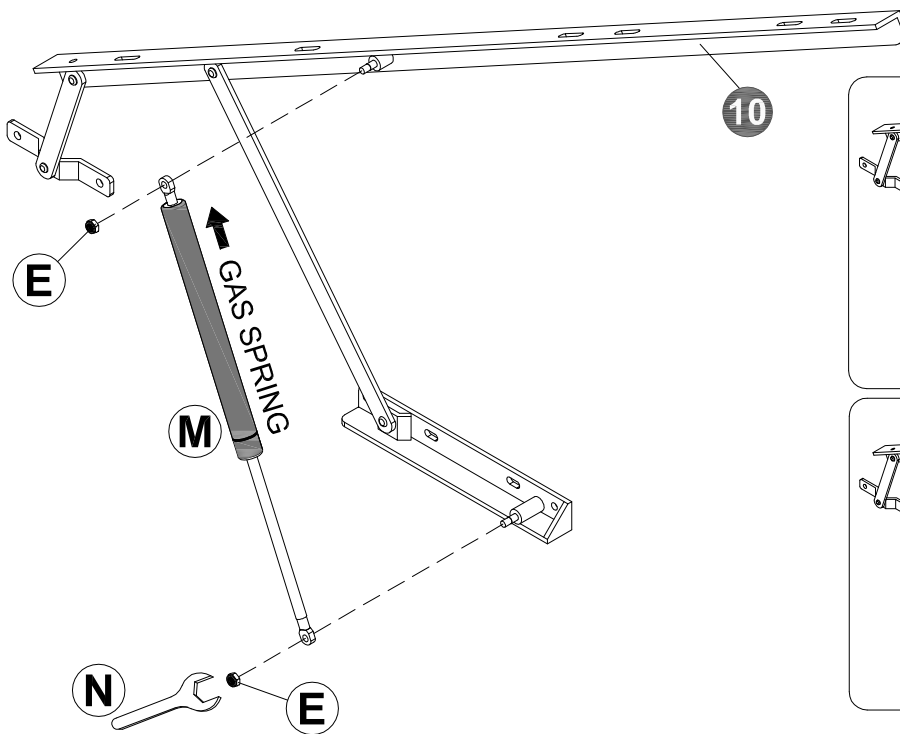
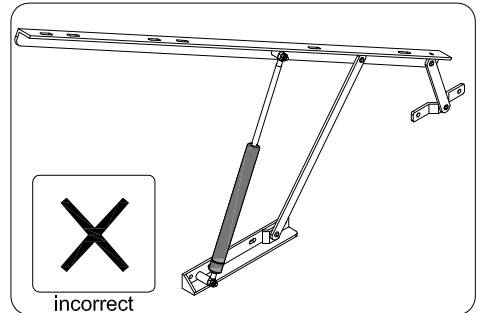
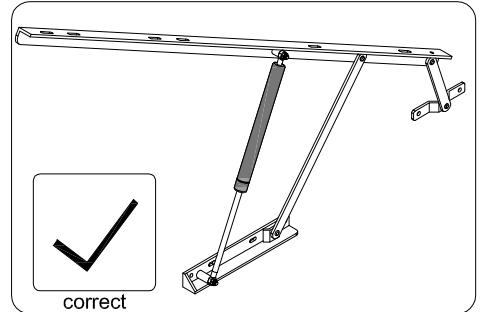
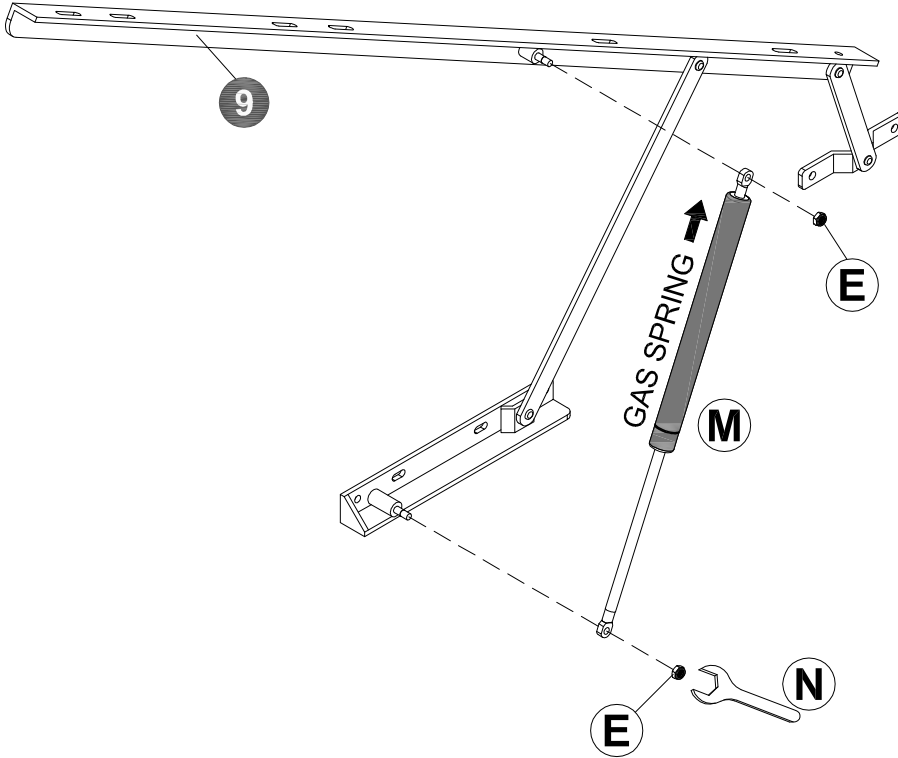

Fully tighten all nuts after attaching the pistons, ensuring they are correctly fitted as per diagram.

STEP 8



K x 1



O x 2

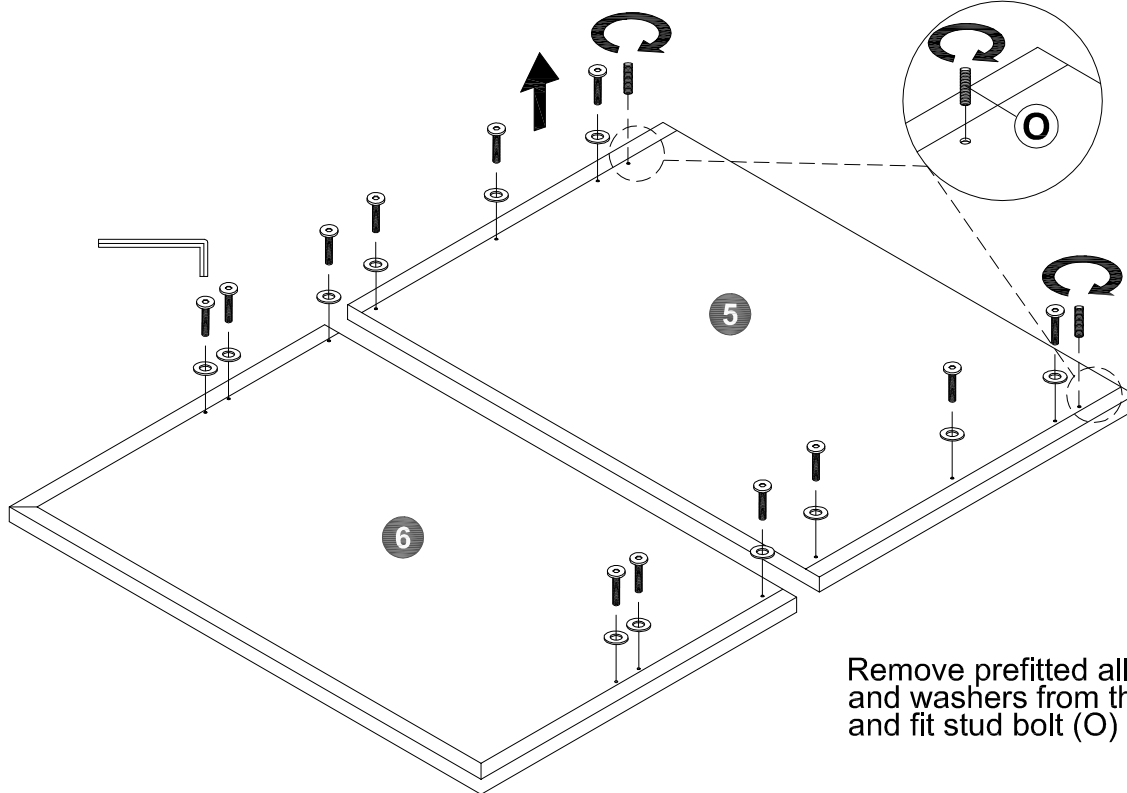

Remove prefitted allenhead screws and washers from the base boards and fit stud bolt (O) as shown.

STEP 9

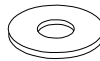

A x 2

C x 4

F x 4

I x 2

L x 1

K x 1

Attach lifting straps and mattress support using provided fixings and allen key as shown.

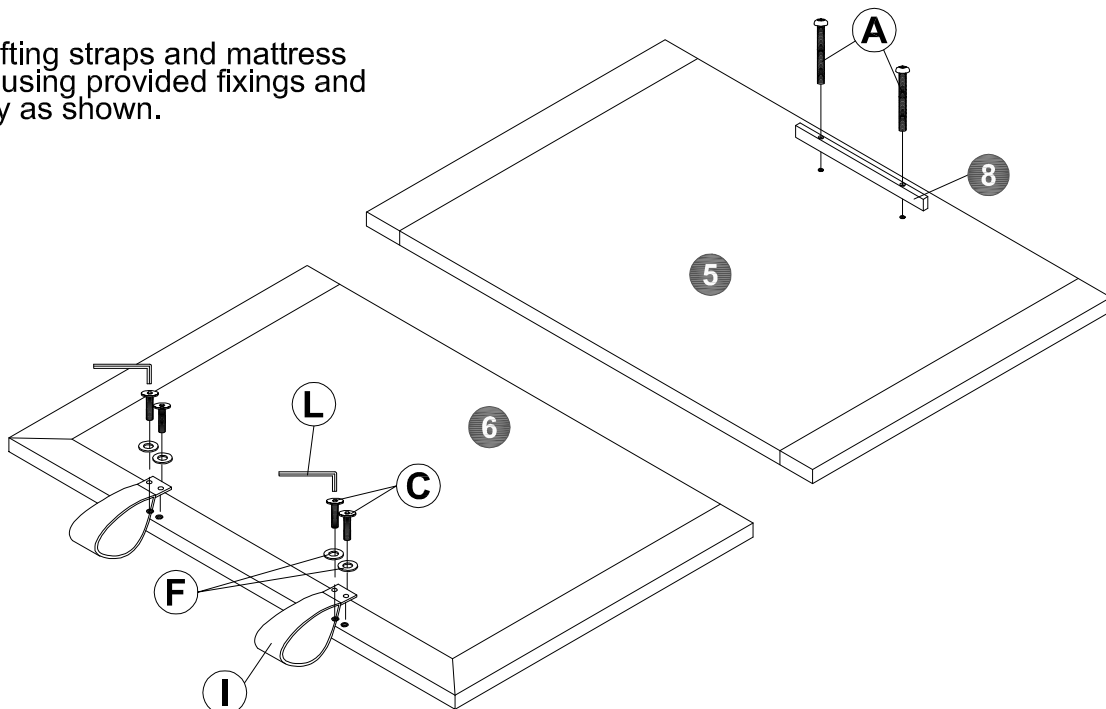

STEP 10



K x 1

1. First put the base (5) on the top of mechanism (9) & (10) and fix with the pre-installed stud bolt (O) to the first locating hole to prevent the lift base from dropping down.
2. Use Allen head screw and flat washer to fully tighten all others screws as shown.
3. Take care not to damage the bottom cross rails.

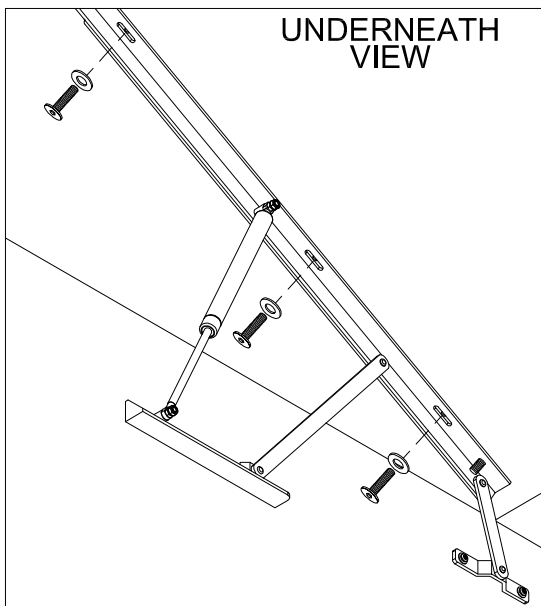
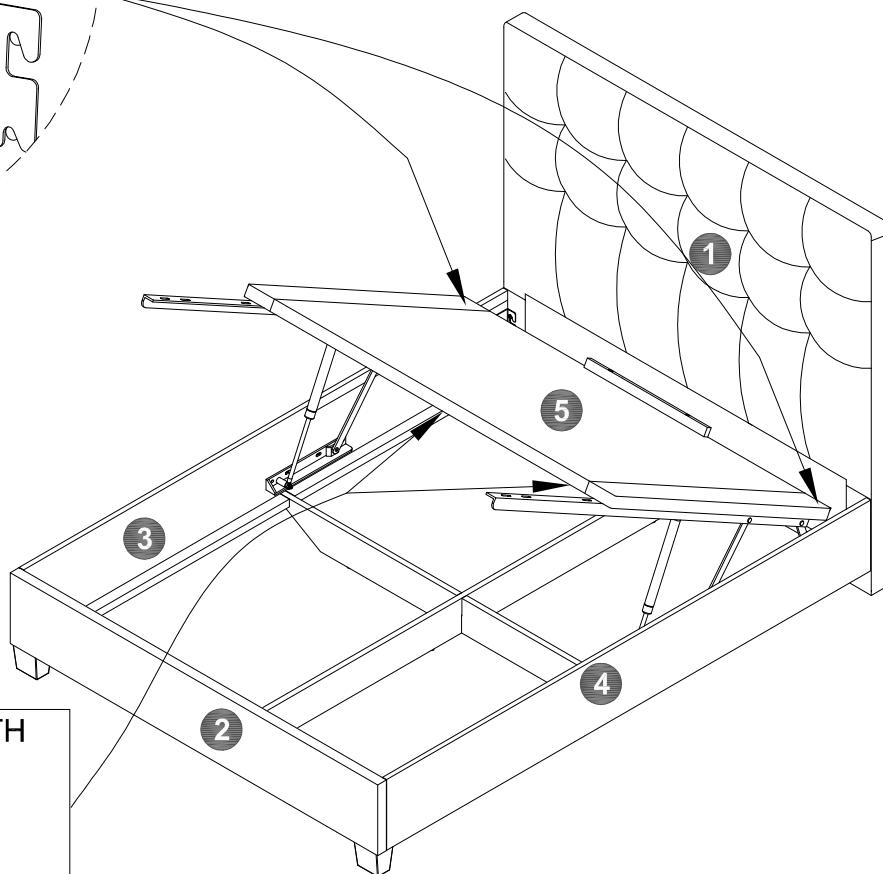
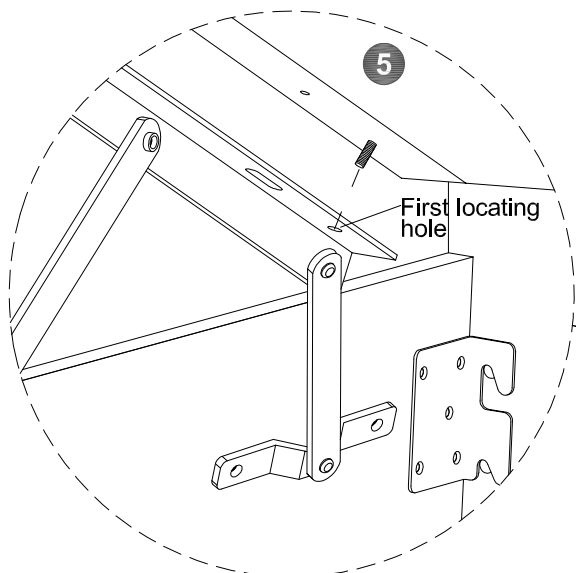

STEP 11

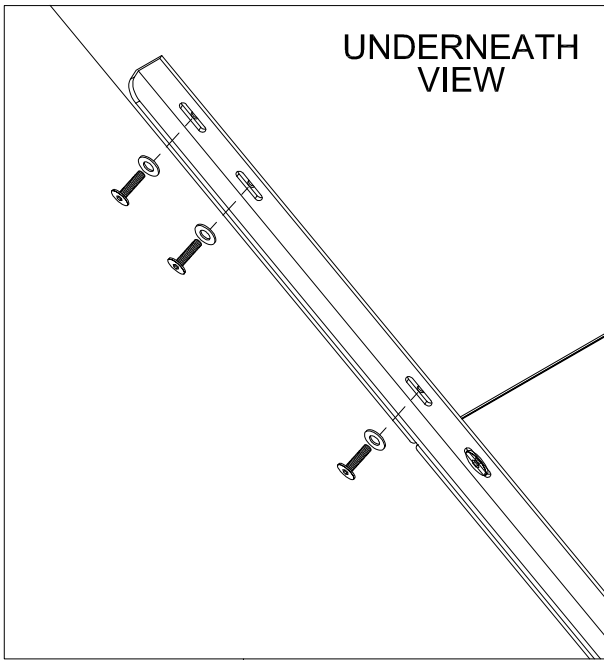
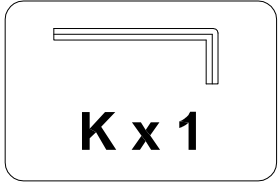

Place lift base (6) on top of mechanisms and attach as per base 5

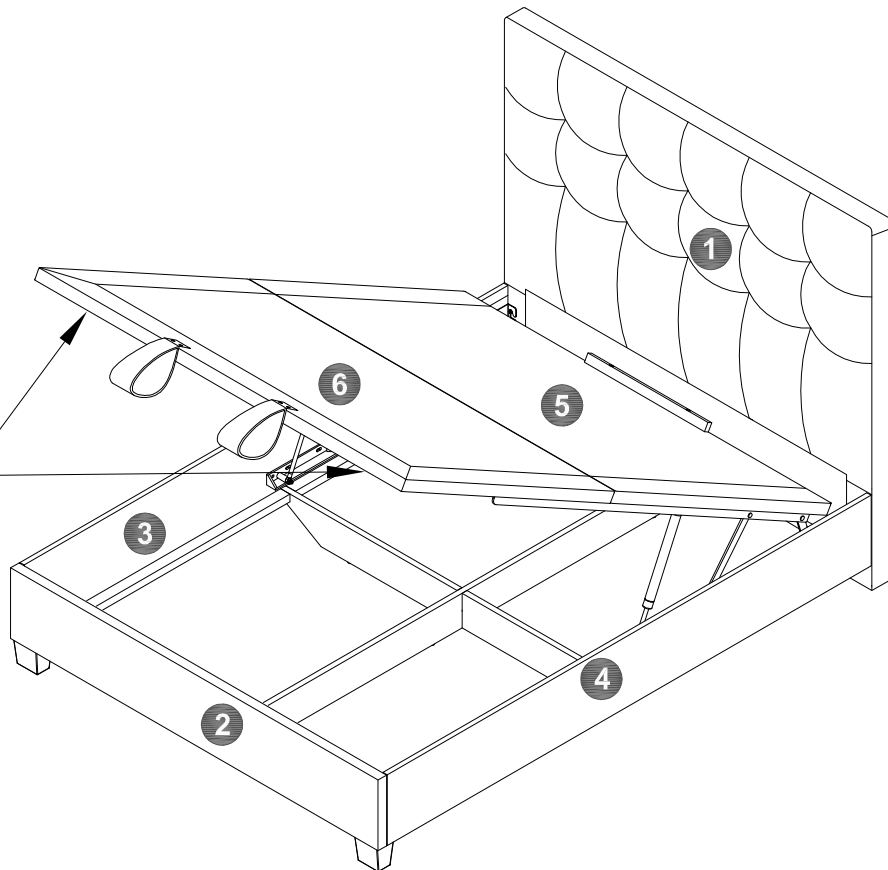

STEP 12

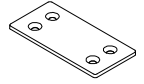

D x 8

H x 2

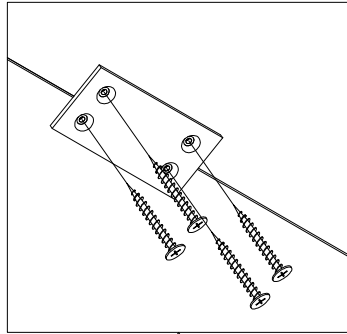

Affix metal plates to the underside of the mattress bases with fixings and screwdriver provided.

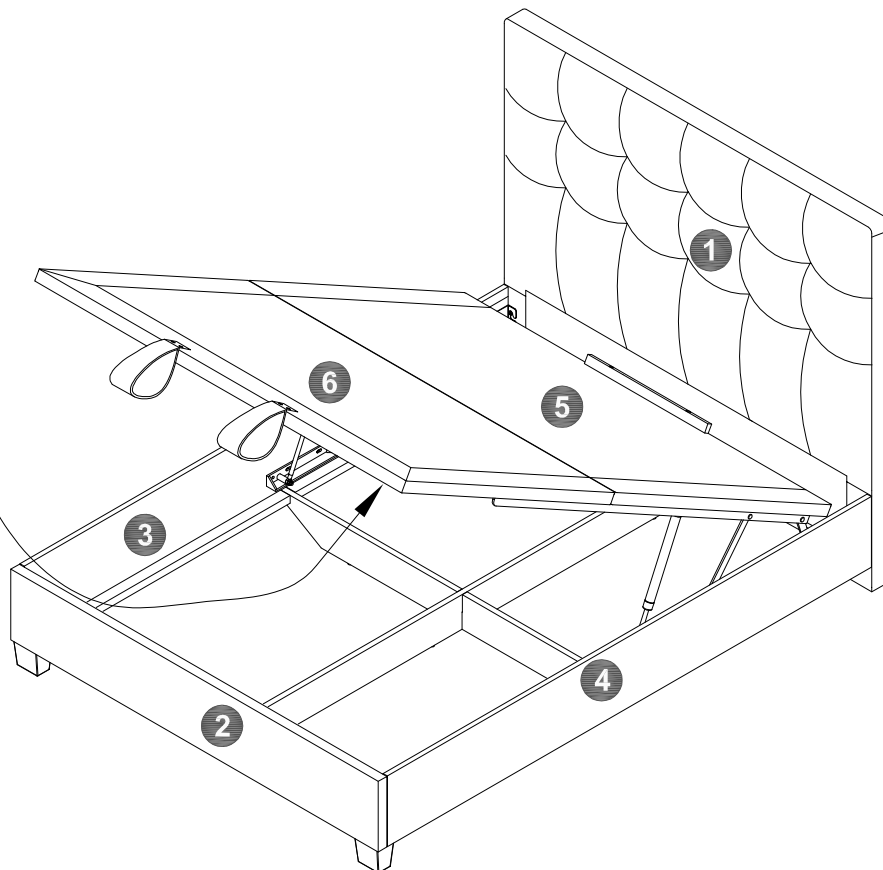
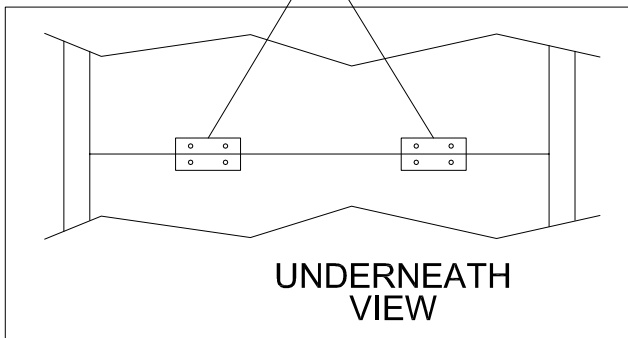

STEP 13

Slide base panels into place, taking care not to catch them on the side mechanisms.

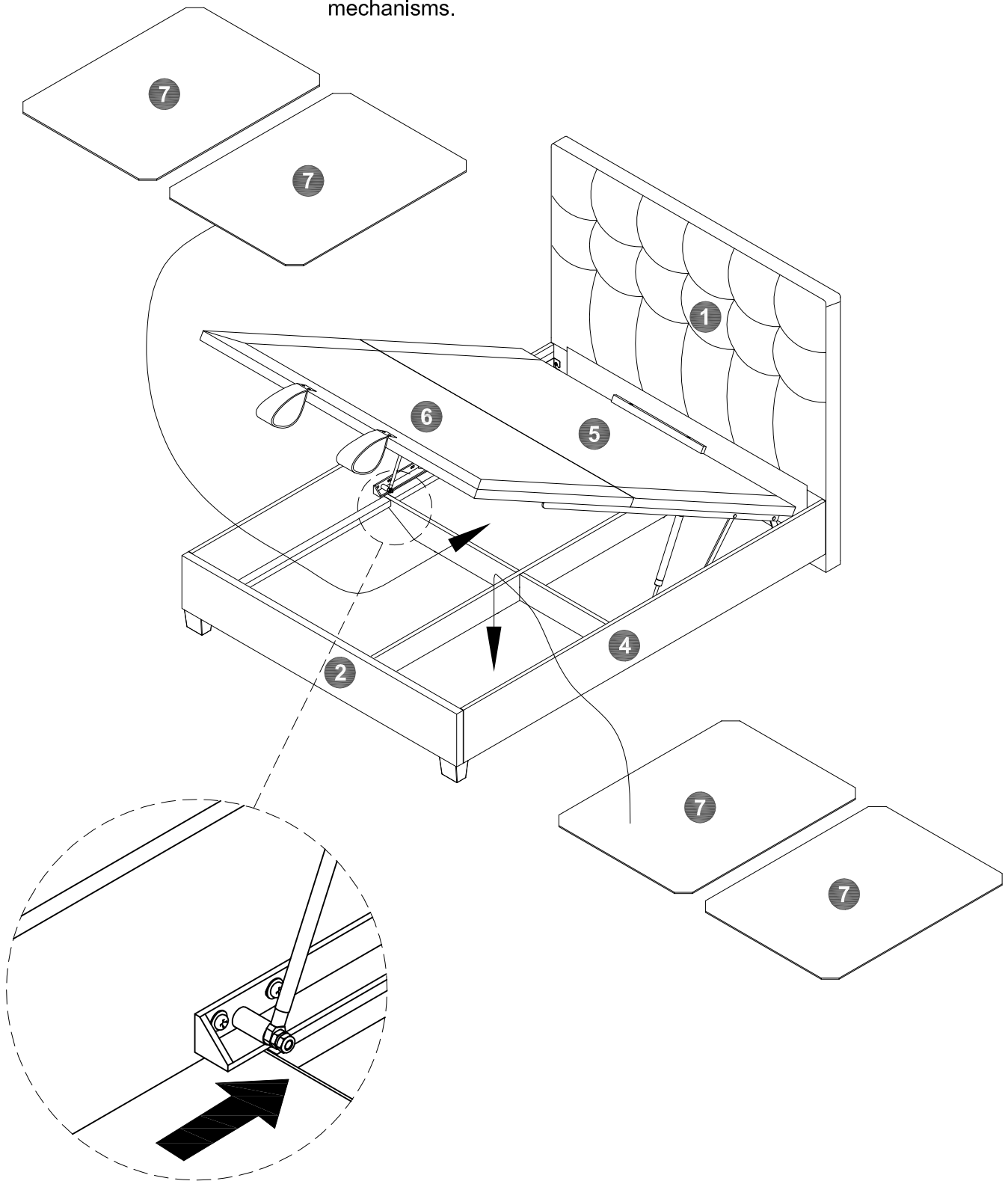

STEP 14

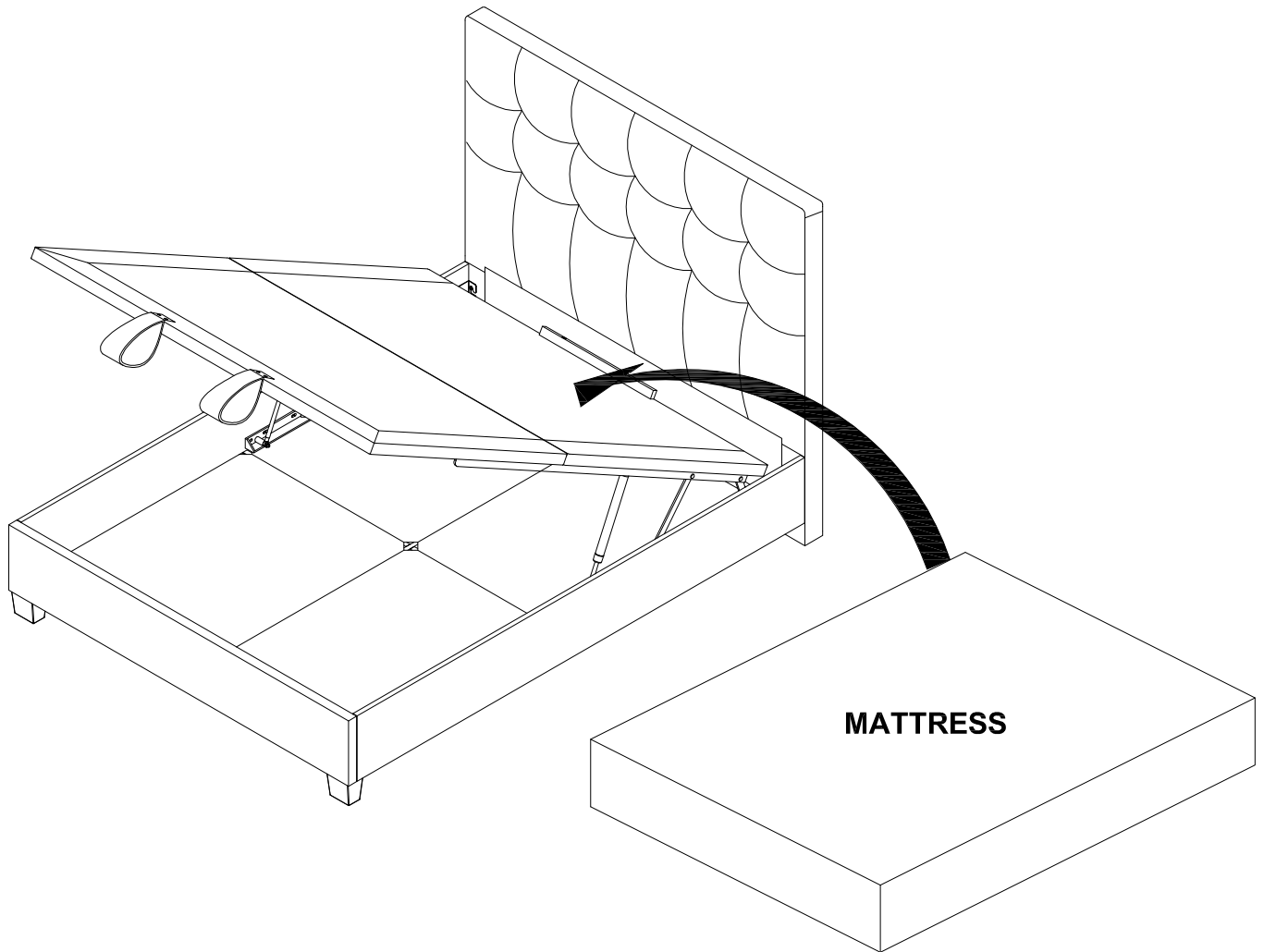

A. This Lift Mechanism provides assistance with the lift of the mattress fitted to the base - it does not lift the mattress for you. The system has been designed to effectively lift the base system fitted with a variety of mattress weights and combinations of depth. The combination of mattress weight and depth determines the degree of assistance provided by the mechanism.

B. Following installation of the mechanism lift / pull the base up and down a few times to free off the system. The gas cylinders fitted to the system may be stiff when first used or if the system has not been operated for a period of time. The mattress must be fitted to the base.

C. Use the strap handles to lift up the mattress base using two hands - Pull the mattress base down using two hands equally spaced from the centre of the mattress base. **DO NOT** pull down on one side of the base only as this is likely to damage the base system with potential failure of the mattress base system and lift mechanism. **Do not operate the lift up mechanism without the mattress fitted to the base.**

CAUTION : Do not allow children to operate the lift Mechanism.
Do not allow children near the lift base when operating the Mechanism.
Do not allow children in the area of the internal storage base.
Keep hands clear of the mechanism when operating the base system.
Do not stand inside the bed / on the internal storage base.
Do not overload the internal storage base.

STEP 15

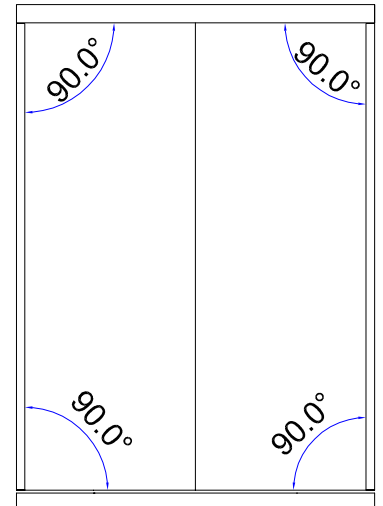
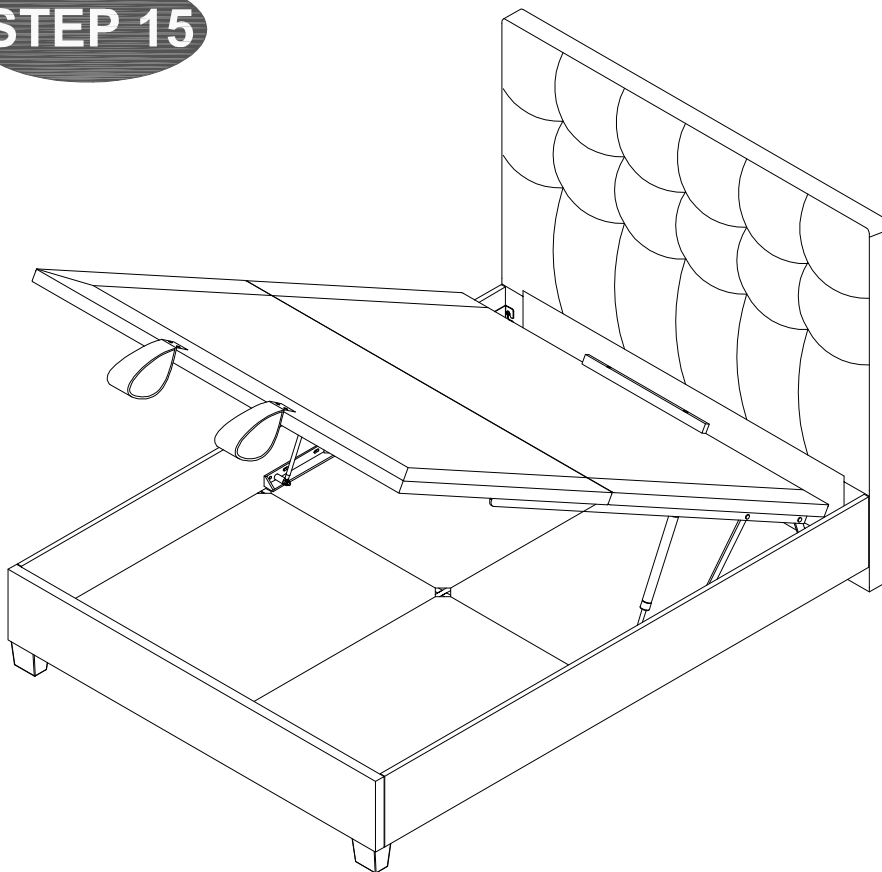

~ Make sure the Bed Frame 4 side angles are at 90 degrees before you closing the lift base.

STEP 16

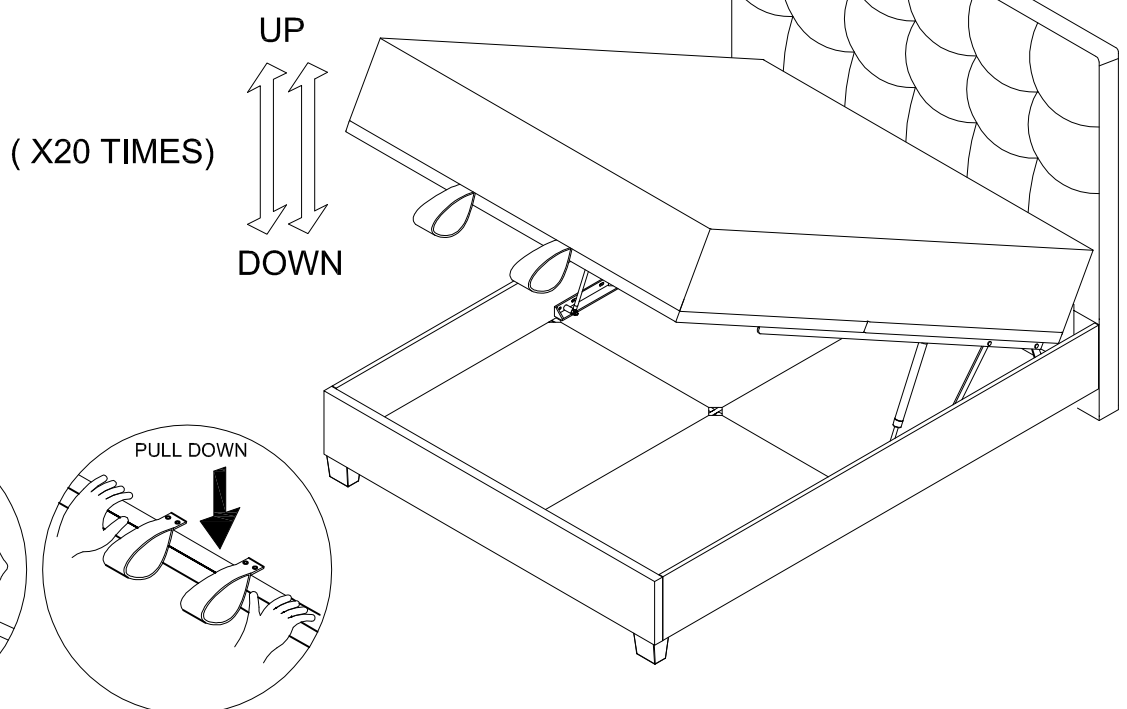

~ The mattress must be fitted to the base. (Do not operate the lift up mechanism without the mattress fitted to the base.)

~ Lift Up and Down the Lift-Up Frame with Mattress at least 20 times before use.