

## Step 20

- Connecting the audio system (WOOFER/AMP)
- Ensure the power is switched to the off position.
- Attach the Hub (S) into Hub 1 socket as shown.
- Ensure both Hub retainer screws (S) are fully tightened.

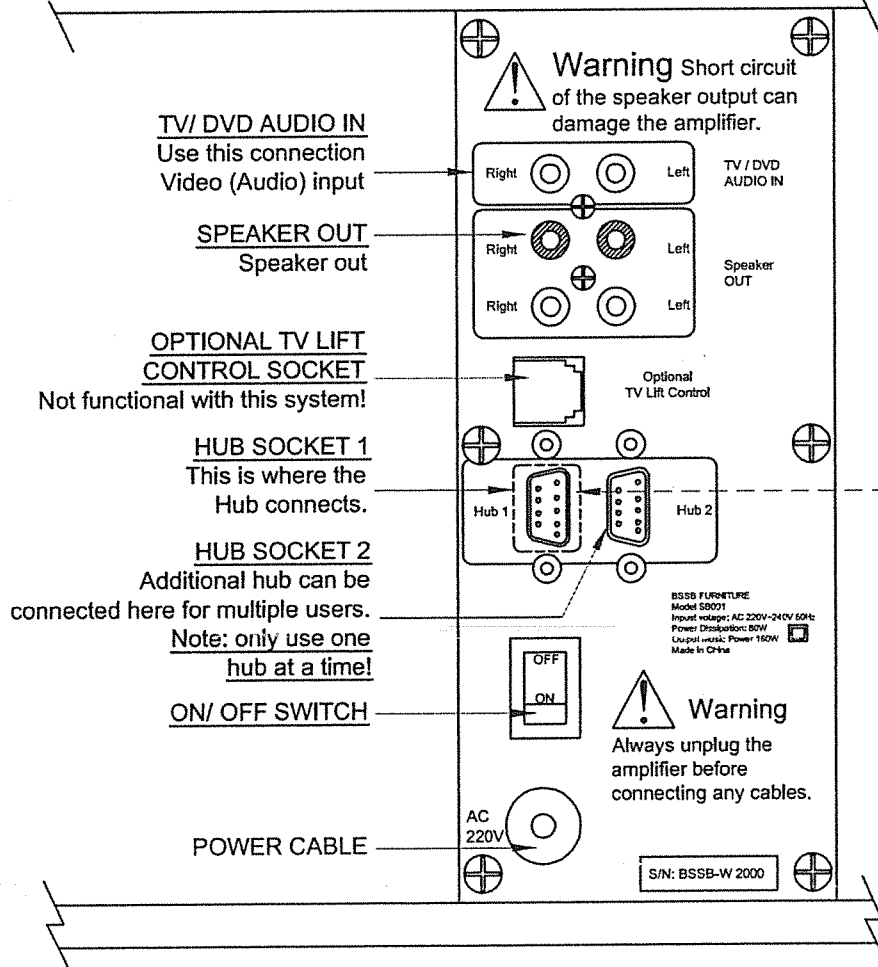
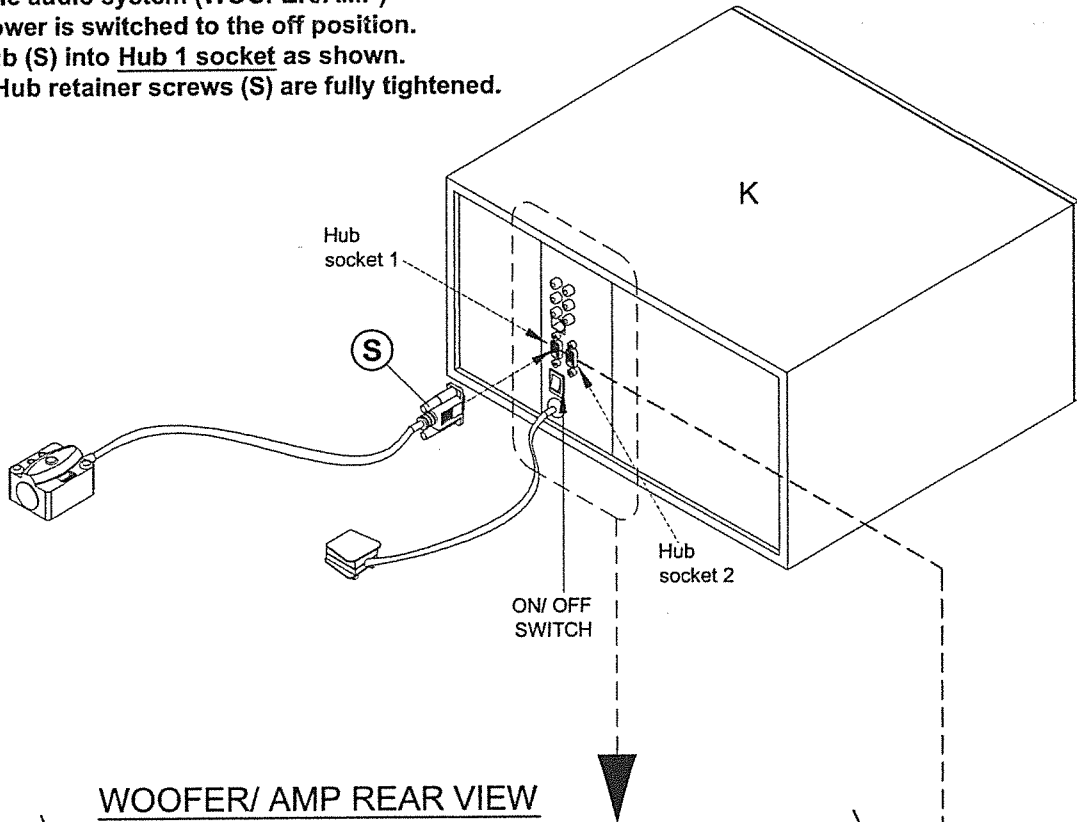

## Step 21

- Place the Woofer/AMP between the Footboard & DVD/Media compartment as shown.

**STEP 21-1** Connect the left and right speaker to the left and right socket location in back side of woofer/AMP as shown.

**STEP 21-2** Connect the Woofer/AMP power plug to the mains supply (you may require an extension lead for this).

**STEP 21-3** Switch "ON" the main power supply.

**STEP 21-4** Switch "ON" the Woofer/AMP, after 2~3 seconds you will hear the power on Audio notification . ( A blue light will appear on the hub select button )

**STEP 21-5** Power Woofer/AMP "OFF" before continuing to the next stage of setup.

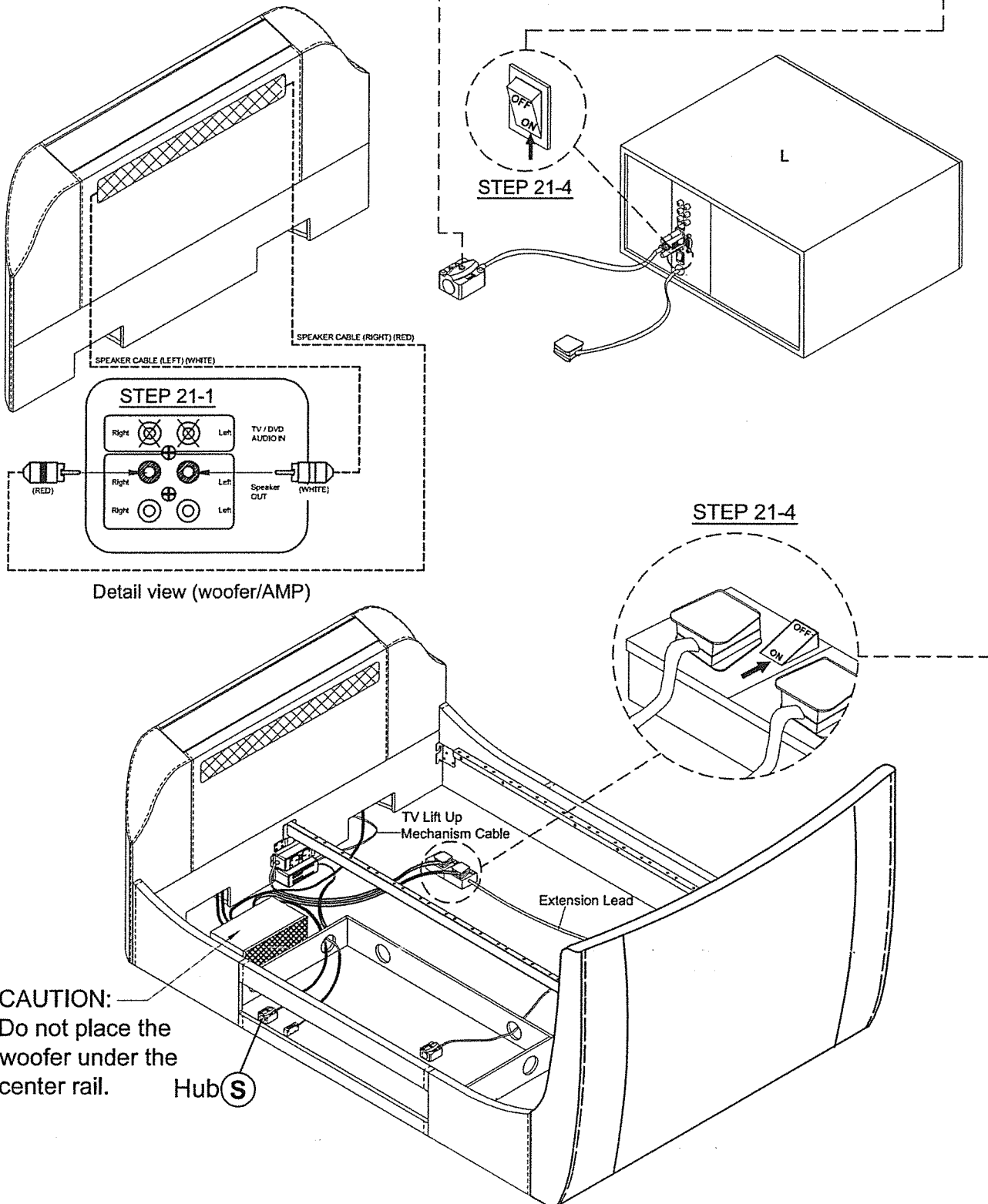

## Step 22

- Connecting your TV to the TV bed speaker system.

### Connection plan 1 (as shown)

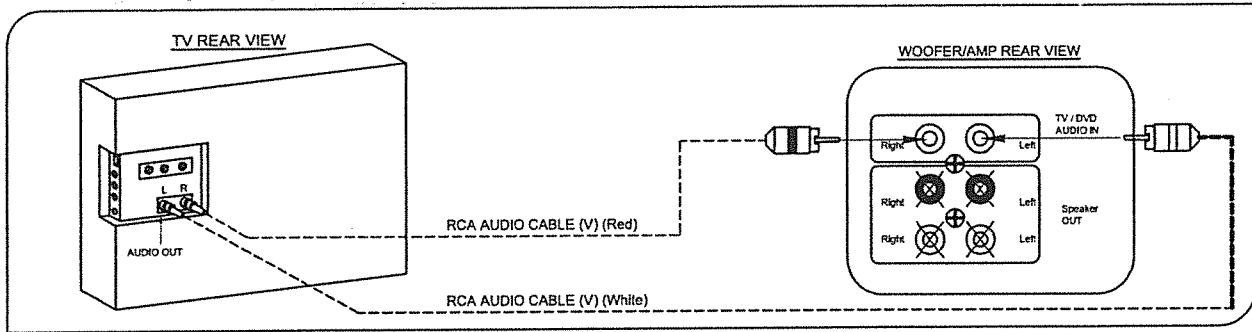

### Connection plan 2 (as shown)

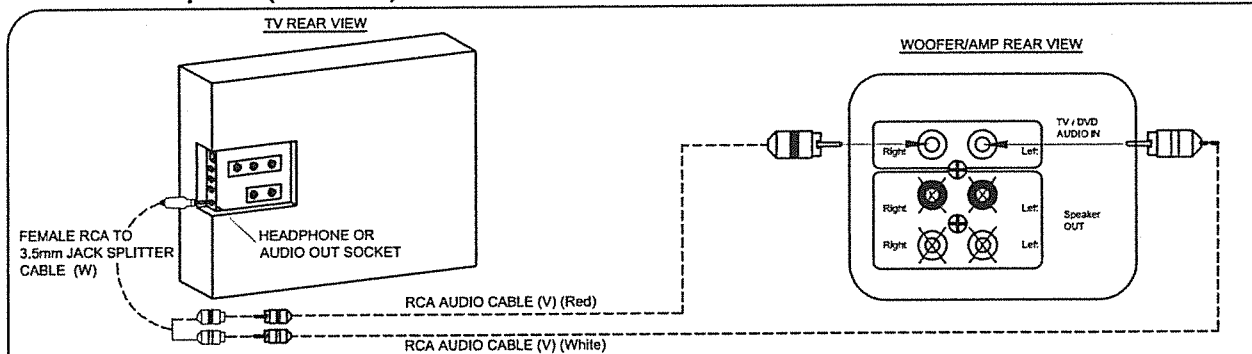

Please note some Television's have an audio setting that will allow the user to select an external speaker. Please see your Television user manual for further guidance.

### Step 22-1 TV/DVD

- Your TV bed system is now ready to play audio from you television.
- Switch your woofer/AMP power "ON" after 2~3 second you will hear the power on audio notification.
- Turn the TV "ON" (ensure it is playing an audio/video " broadcast")
- Press the wireless remote control TV/DVD button in (Audio select) on your remote control.
- You should now be able to hear the sound from the TV, speaker and woofer.
- Please use volume, base and treble buttons on you wireless remote control to select your preferred acoustic sound level.

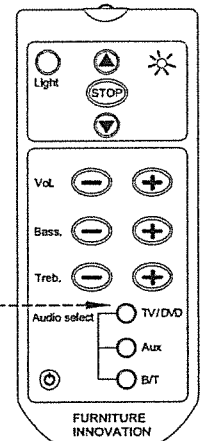

Wireless remote control

### TROUBLE SHOOTING

- In the event there is no audio sound from the TV bed speaker system, please follow the points shown below.
- Make sure the main power supply is "ON" and also the woofer/AMP power is switch "ON". (Hub select button should be illuminated with a blue light)
- Check the cable connections and make sure all the cables are securely in place. TV, Speaker, Woofer/AMP etc.
- Make sure the wireless remote control is working by pressing any button on the remote control and the blue LED in the top right hand corner of remote control lights up. ( if the remote control is not working please replace the batteries see "Step24 / Pages 27 of 34" )
- Make sure the TV audio/video volume is turned up.
- Make sure the wireless remote control TV/DVD button (Audio select) is pressed.
- Make sure the wireless remote control linking the woofer/AMP is working properly. In the event your remote control is not responding, please synchronize the wireless remote control through "Step25 / Pages 28 of 34". "Wireless remote control notification"
- In the event you are unable to get you remote control working, it is possible to control you TV bed speaker system via the Hub. To do this "press & release" the audio select button until audio is acknowledge. See "step 23 pages 26 of 34" for further Hub detail.
- Please note: In some instances the TV speaker may produce sound as well as the TV bed speaker system. In this instance please lower your TV volume to minimum, you should still hear sound from you TV bed speaker system. Some Television's have an audio setting that will allow the user to select an external speaker. Please see your Television user manual for further guidance, if applicable.

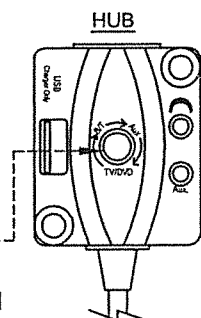

## Step 22-2 Playing audio files through BLUETOOTH connection.

- The woofer/AMP is bluetooth compatible and will work wirelessly with most bluetooth compatible Audio devices. Please refer to your device manual for further information on how to enable its bluetooth function and search / pair with your woofer/AMP.
- Press the wireless remote control B/T button in (Audio select) on your remote control.
- Once you have prepared your device to search for a bluetooth (wireless) device - your Woofer/AMP will show up as "F I SPEAKER " or "00:15- -" depending on you bluetooth device type. Once you have opted to (PAIR/CONNECT) with BLUETOOTH Woofer/AMP - your device will ask you for a connection PIN.
- To PAIR, enter PIN (0000) - four zero's!
- Once your device has successfully connected to your Woofer/AMP you can hear the audio notification bleep - this confirms the Woofer/AMP Bluetooth is enabled and ready to use.
- Please ensure your device volume is turned up at least half way and the B/T button is selected.
- you can simply use your device's music player to play sound through your Woofer/AMP - ENJOY
- Please use volume, base and treble buttons on your wireless remote control to select your preferred acoustic sound level.

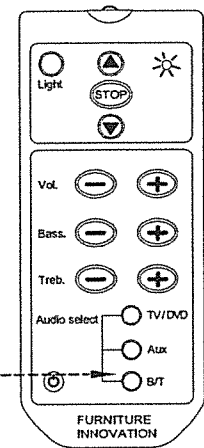

Wireless remote control

**Bluetooth Connection Notification:** The Woofer/AMP is only able to connect/pair with one device at a time using Bluetooth connectivity. In the event you wish to connect/pair an alternative/additional Bluetooth compatible device, please firstly disconnect the bluetooth connection between your current device and the Woofer/AMP. Then again repeat the above steps .

### TROUBLE SHOOTING

- In the event there is no audio sound from the TV bed speaker system, please follow the points shown below.
- Check your device has successfully connected / Pairing to your Woofer/AMP. You can hear the audio notification bleep.
- Check your device is playing music and the volume is turned up at least half way.
- Make sure the wireless remote control is working by pressing any button on the remote control and the blue LED in the top right hand corner of remote control lights up. ( if the remote control is not working please replace the batteries see "Step24 / Pages 27 of 34" )
- Make sure the wireless remote control B/T button (Audio select) is pressed.
- In the event your remote control is not responding, please synchronize the wireless remote control through "Step25 / Pages 28 of 34". "Wireless remote control notification"
- In the event you are unable to get your remote control working, it is possible to control your TV bed speaker system via the Hub. To do this "press & release" the audio select button until audio is acknowledged. See "step 23 pages 26 of 34" for further Hub detail.

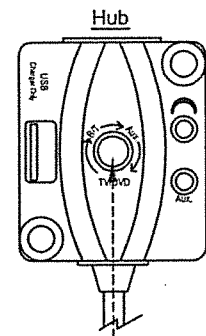

Please see your external devices user manual for additional connection information. Especially if you are experiencing Bluetooth connection issues!

In the event you are experiencing any technical difficulties with your products mechanical electrical function (before contacting your supplier for assistance) please visit <http://furnitureinnovation.freshdesk.com> where you will find quick step guides to rectify common issues.

### Step 22-3 Playing audio files through AUX connection.

- Press the wireless remote control AUX button (Audio select) on the remote control.
- Using the 3.5mm JACK AUX Cable (X) plug directly into any audio device that has a headphone socket and plug the opposite end into Hub AUX socket to deliver wired audio, in the event you have chosen not to connect wirelessly via Bluetooth.
- Please use volume, base and treble buttons on you wireless remote control to select your preferred acoustic sound level.

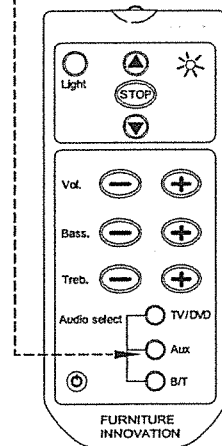

Wireless remote control

### TROUBLE SHOOTING

- In the event there is no audio sound from the TV bed speaker system, please follow the points shown below.
- Check the 3.5mm JACK Cable connections are securely in place to your headphone socket and Hub.
- Check your device is playing music and the volume is turned up at least half way.
- Make sure the wireless remote control is working by pressing any button on the remote control and the blue LED in the top right hand corner of remote control lights up. ( if the remote control is not working please replace the batteries see "Step24 / Pages 27 of 34" )
- Make sure the wireless remote control AUX button (Audio select) is pressed.
- In the event your remote control is not responding, please synchronize the wireless remote control through "Step25 / Pages 28 of 34". "Wireless remote control notification"
- In the event you are unable to get you remote control working, it is possible to control you TV bed speaker system via the Hub. To do this "press & release" the audio select button until audio is acknowledge. See "step 23 pages 26 of 34" for further Hub detail.

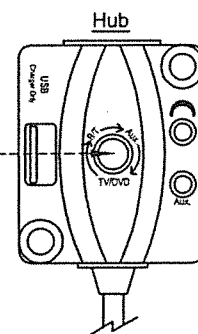

### Step 23 HUB DETAIL

#### AUDIO FUNCTION SELECT BUTTON

In the event you are expressing difficulties with you remote control - Once you have chosen your method of audio connection (TV/DVD , BLUETOOTH or AUX device) use this "press & release" button to switch between functions.

#### HEADPHONE SOCKET

If you receiving audio from a video device, you can plug in a headphone set to avoid disturbing others.

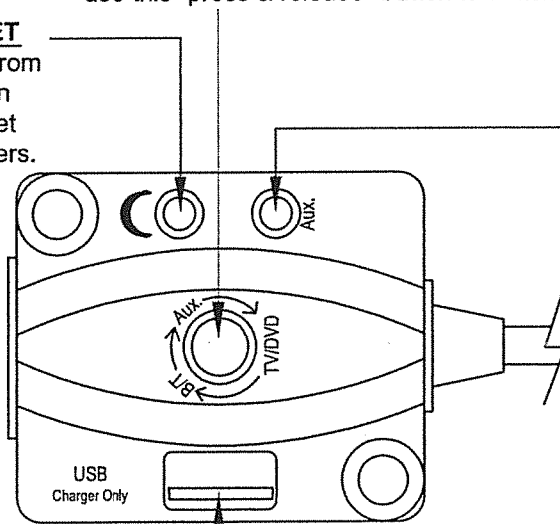

USB PORT  
charge only

#### AUX SOCKET

Use 3.5mm JACK AUX Cable to plug directly into any audio device that has a headphone socket and plug the opposite end into Hub AUX socket to deliver wired audio, in the event you have chosen not to connect wirelessly via Bluetooth.

**Step 24 WIRELESS REMOTE CONTROL DETAIL**

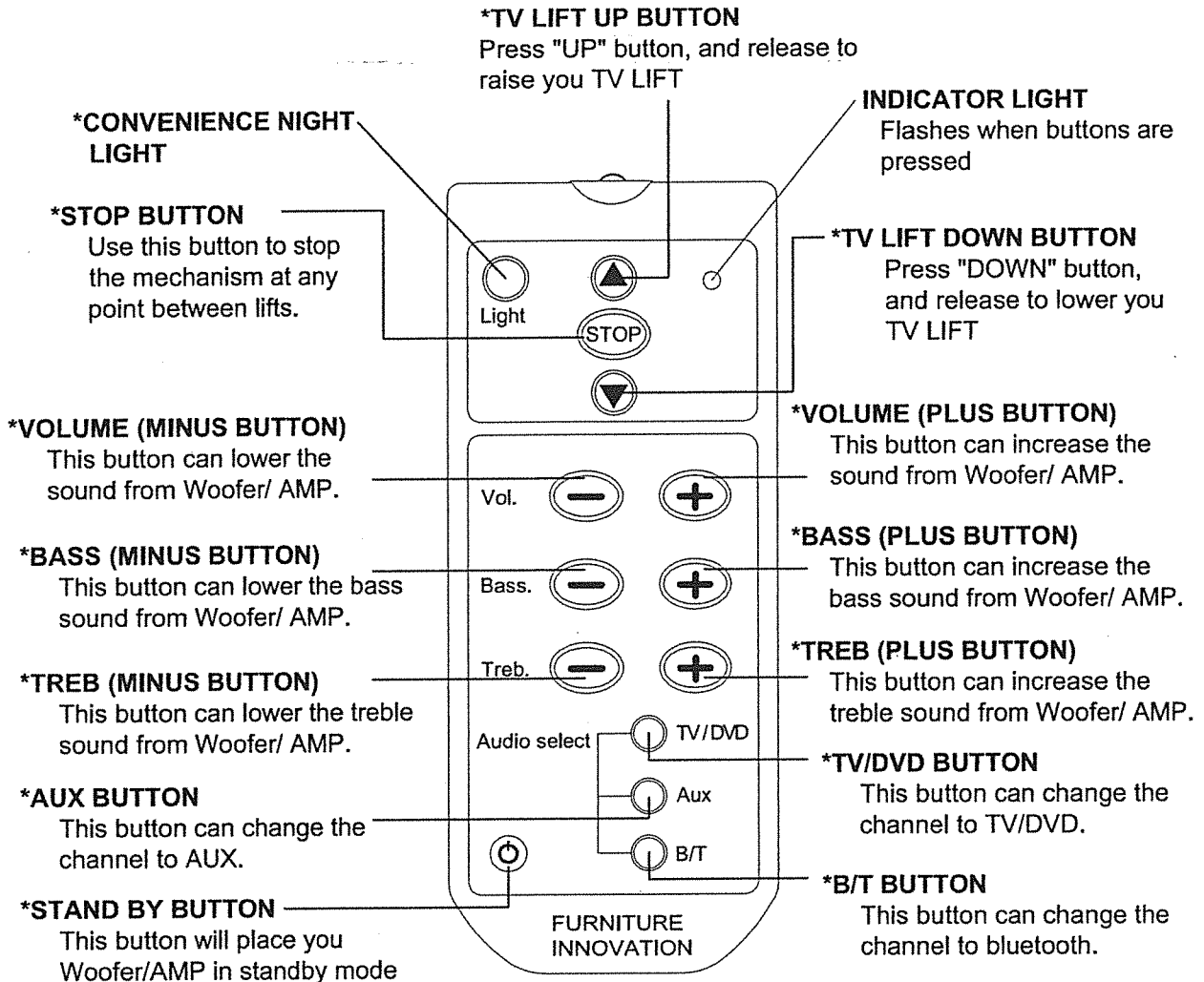

**CHILD-LOCK SAFETY FEATURE:**

To avoid unattended children from operating the TV lift system the Lift can be locked by holding **STOP BUTTON** on Remote Control for at least 6 seconds, When the lift is locked, it will stop working and the Remote Control cannot operate. To unlock the lift, press Stop button on Remote Control for at least 6 seconds. (OR Turn off power for 6 seconds.)

**Battery:**

Size: AAA - Ø10.5 X T44.5mm

Spec.: 1.5V

Pull out the battery case from here to open

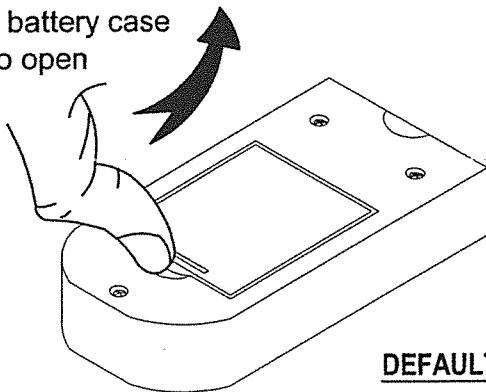

(AAA) Battery x 3pcs (provided) install to battery case.

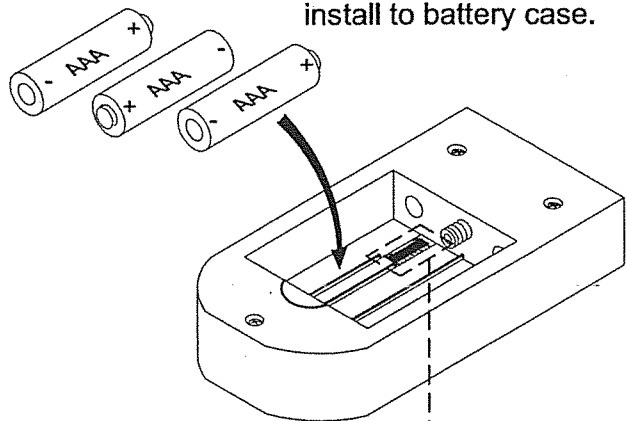

**DEFAULT SETTING**

ALL SWITCHES IN DOWN POSITION  
1 2 3 4 5 6 7 8

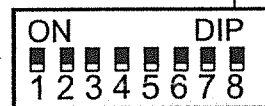

CODE BOX- READ THE IMPORTANT NOTE ON NEXT PAGE.

## Step 25

- Wireless remote control notification.

### ATTENTION - WIRELESS REMOTE NOTIFICATION ( IMPORTANT!!)

This Wireless 'Radio Frequency' Remote control is designed to operate your TV lift Mechanism / Woofer/AMP straight out of the box.

However, in the event the remote is also communicating with other TV Beds / Woofer/AMP in close proximity, which work on the same remote system or if there is interference from other radio frequency devices, please remove the battery case and switch over at least one of the white flick switches on the [CODE BOX] to the ON / DIP position. Then follow the synchronization process shown below for your remote to work only with the bed it is intended for.

#### CODE BOX SETTING

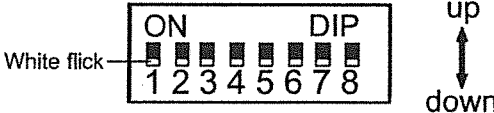
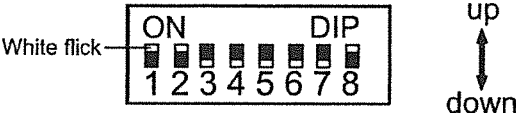
DEFAULT SETTING	SYNCHRONIZED SETTING
	
<p>ALL SWITCHES DOWN / OFF - IS THE STANDARD FACTORY SETTING THAT WILL OPERATE ALL INNOVATION FURNITURE TV BEDS and Woofer/AMP, WITHOUT THE NEED TO SYNCHRONIZE.</p>	<p>SWITCH TO THE ON / DIP POSITION AT LEAST ONE OF THE WHITE FLICK SWITCHES TO ALLOW FREQUENCY SYNCHRONIZATION.</p> <p><u>TV LIFT synchronized setting</u> Ensure the 'Wired Remote Control' is powered "OFF". before powering back on, press and hold either the "UP" or "DOWN" switch on your wireless remote. then while continuing to press this switch "DOWN" power on the wired remote control while keeping the remote control switch compressed for at least 6 seconds.</p> <p><u>WOOFER/AMP synchronized setting</u> Ensure the 'Woofer/AMP' is powered "OFF". before powering back on, press and hold the "standby" button on your wireless remote control. Then while continuing to press this button, power on the Woofer/AMP "ON/OFF" switch while keeping the remote control switch compressed for at least 4 seconds.</p> <p><b>YOUTUBE -SYNCHRONIZE VIDEO LINK</b> <a href="http://www.youtube.com/watch?v=Zqv3107YjG8">http:// www.youtube.com/watch?v=Zqv3107YjG8</a></p>

In the event you are experiencing any technical difficulties and you require additional assistance/support with you product ' Mechanical/Electrical' functions - Please visit <http://furnitureinnovation.freshdesk.com>

## Step 26

- Slat attachment.
- Attach middle caps and end caps to the bent slats as shown.
- Push the caps into the metal frame, follow the steps given.

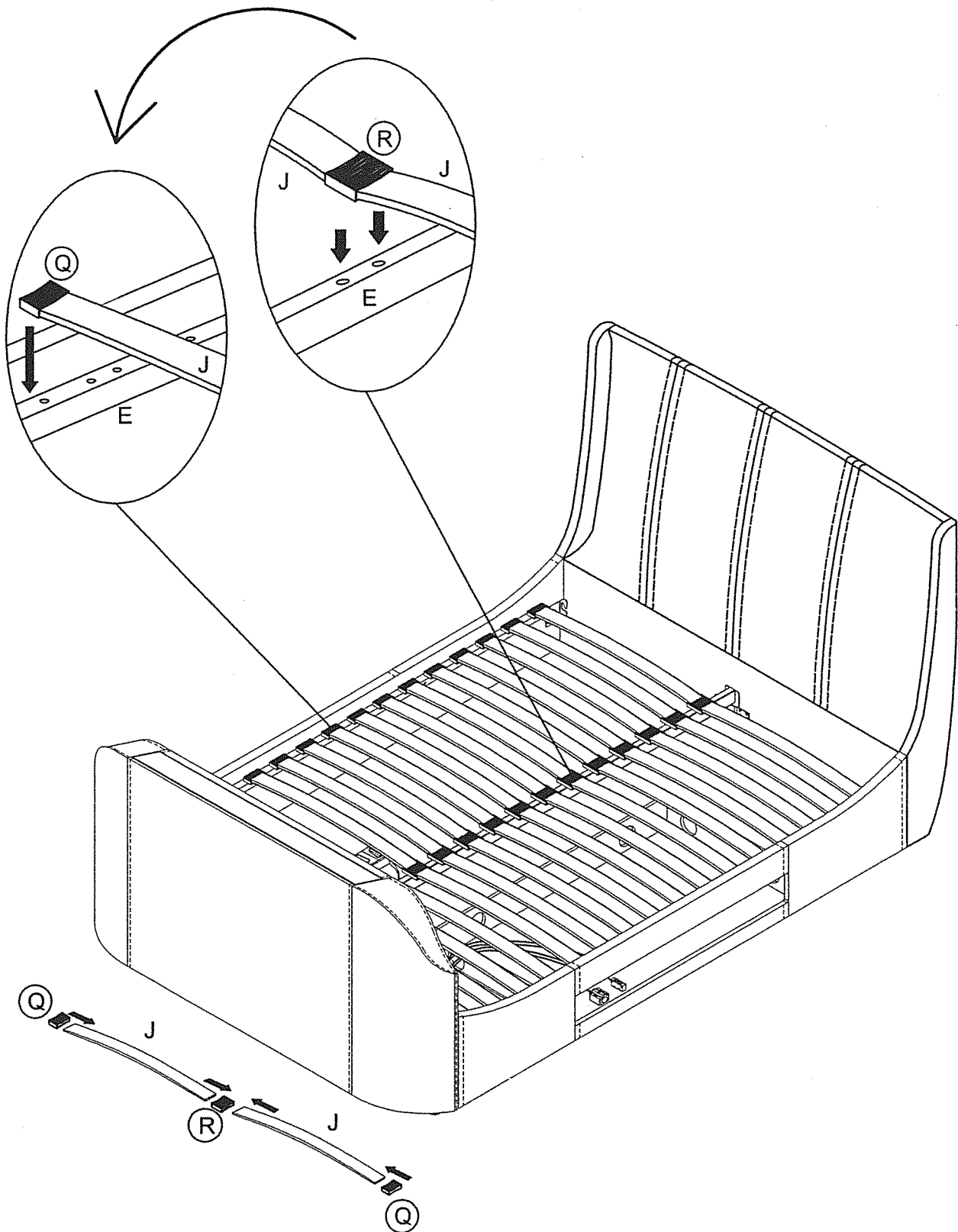



### Step 27

- Attach the Remote Control Pocket to the left or right sides of the side rail as preferred.

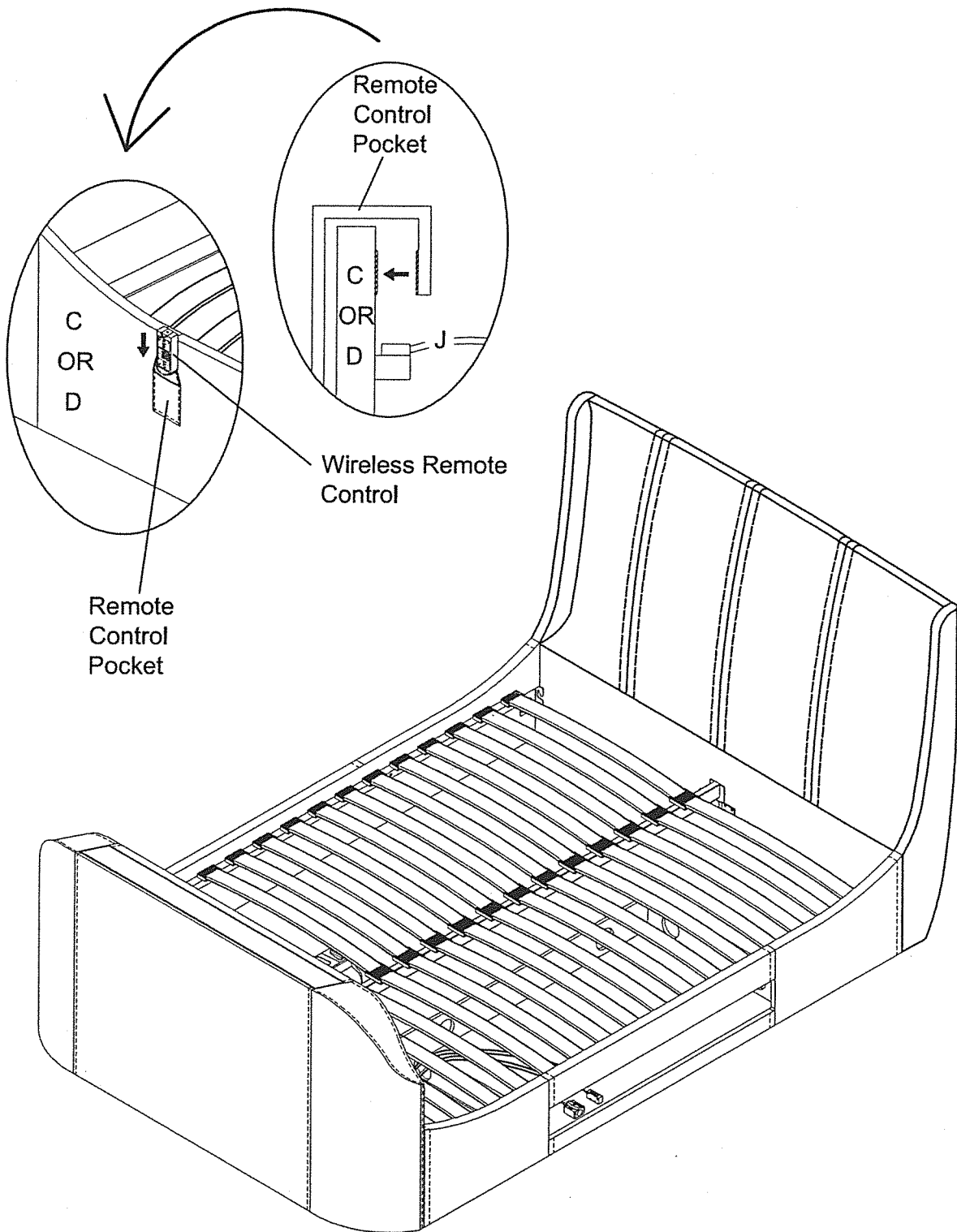

### ATTENTION! PLEASE NOTE:

In the event you are experiencing any technical difficulties and you require additional assistance/ support with your product 'Mechanical/ Electrical' function - Please visit <http://furnitureinnovation.freshdesk.com>

# TROUBLE SHOOTING

Symptoms	Suggested Action
TV lift mechanism 'will not respond' to the 'wired' remote control that is attached to the TV lift control box underneath the mattress.	<ol style="list-style-type: none"> <li>1.Ensure the TV lift control box is receiving 'mains power' (external wall socket power plug-point) test an alternative 'working' electronic device if unsure.</li> <li>2.Ensure the wired remote is plugged firmly and securely into the TV lift control box.</li> <li>3.Ensure the control box LED power light is on.</li> <li>4.Ensure the TV lift power cable is plugged firmly and securely into the TV lift control box.</li> </ol> <p>In the event all the above have been checked and confirmed in position but the TV lift remains unresponsive - please contact your product supplier directly for further assistance.</p>
TV lift mechanism 'works' with the 'wired' remote control. The 'wireless' remote control will not operate the TV lift mechanism.	<ol style="list-style-type: none"> <li>1.Ensure there are three working AAA batteries in the remote control and the top right hand corner LED lights up blue when pressing any button on the control panel (if the batteries are working but the LED light is 'not' responding - please contact your product supplier directly for further assistance).</li> <li>2.Switch the wired remote control OFF and ON again.</li> <li>3.Ensure white dip selector switches inside the remote control battery case are all switched in down position 1 2 3 4 5 6 7 8 - default setting. (Refer to Assembly Instruction -Remote Control Detail)</li> <li>4.Try to synchronize the remote control with the control box by: <ul style="list-style-type: none"> <li>✓ Switch off the TV lift control box via the 'wired' remote.</li> <li>✓ Wait for 30 seconds.</li> <li>✓ Press and hold any of the buttons on the 'wireless' remote control.</li> <li>✓ While keeping the button pressed on the remote, quickly switch the 'wired' remote on and wait for 6 seconds.</li> <li>✓ Release the 'wireless' remote button and test again.</li> </ul> </li> </ol> <p>In the event the TV lift remains unresponsive - please contact your product supplier directly for further assistance.</p>

## SPECIFICATION

FEATURE	1. Wireless Remote Control 2. Wired Remote Control
VOLTAGE	US 120V/60Hz 100V/60Hz EU 240V/50Hz 220V/50Hz
MAXIMUM LOADING	80lbs
CONSUMPTION POWER	100Watts
UPWARD SPEED	1"/1.5Sec.
BATTERY (WIRELESS REMOTE CONTROL)	Size: AAA - Ø10.5 X T44.5mm Spec.: 1.5V

### SPECIAL NOTE:

THE PRODUCT SERIAL NUMBER CAN BE LOCATED ON THE TOP OF MECHANISM AND CONTROL BOX AND SHOULD BE QUOTED WHEN ORDERING / REQUIRING SPARE PARTS OR SERVICE ASSISTANCE.

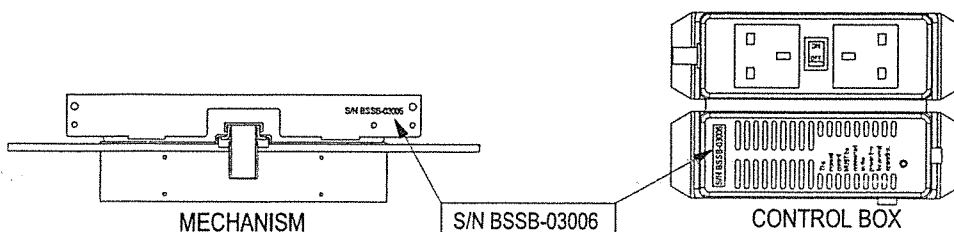

# TV LIFT MECHANISM-PARTS LIST

## NO. DESCRIPTION

1. Control Box
2. Manual ON/OFF Switch
3. Power Outlet
4. 4 Wire plastic connector(female)
5. 8 Wire plastic connector(female)
6. Upgradeable wire remote socket
7. Wired remote control
8. ON/OFF switch
9. UP/DOWN switch
10. 4 Wire plastic connector(male)
11. Wireless Remote Control
12. Main Assembly
13. Platform
14. TV Flat Bracket (Vesa Bracket)
15. Sliding Bar
16. Gooseneck
17. Upper Hanging Bracket for Assembly x 2pcs
18. Bottom Hanging Bracket for Assembly x 1pc
19. Tool Free Screw x 2pcs
20. M6 Washer x 2pcs
21. Balance grub screw M6 x 15mm x 2pcs
22. Stopper grub screw with Nut M6 x 25mm x 1pc
23. TV block x 2pcs
24. Rubber Pad x 2pcs
25. Screw M4 x 16mm x 4pcs
26. TV Tray
27. Allen Head Screw with washer M6x 20mm x 2pcs
28. Allen Head Screw M6x 20mm x 4pcs
29. Allen Head Screw M8x 16mm x 2pcs
30. Shake proof washer M8 x 16mm x 2pcs
31. Cable Clip 2Pcs - Use to fix wire
32. Cable Ties 2Pcs - for use to fix cable / wire
33. Aerial Connection X 1pc
34. Allen Key M5 1Pc - Use to adjust Main Assembly
35. Allen Key M3 1Pc - Use to adjust Main Assembly
36. Pan Head Screw M4x 16mm x 2pcs
37. Pan Head Screw M5 x 16mm x 2pcs
38. Pan Head Screw M6 x 16mm x 4pcs
39. Pan Head Screw M8 x 16mm x 2pcs
40. M5 Washer x 2pcs
41. M6 Washer x 2pcs
42. M8 Washer x 2pcs
43. Plastic collar x 2pcs
44. Remote Control Pocket x 1pc
45. 90 Degree HDMI Cable adaptor x 1pc

REFER TO LAST PAGE 34  
KF3001 SPARE PARTS IDENTIFICATION SHEET,  
WHEN ORDER THE SPARE PARTS.

